

# *Operator's Manual*

## Fiberoptic Transmitter

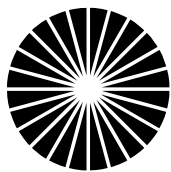
Model 3120A/10357A

10-200 MHz

## Fiberoptic Receiver

Model 4120A/10457A

10-200 MHz



Making Light *Work* For You

**ORTEL**<sup>®</sup>  
CORPORATION

2015 West Chestnut Street  
Alhambra, California 91803  
[www.ortel.com](http://www.ortel.com)

**Ortel Corporation**  
**Model 3120A/10357A Transmitter**  
**Model 4120A/10457A Receiver**

**Operating Manual**  
**IF Fiberoptic Link**

---

File: G:\EDC\DOCSRLSD\MAN\VLC-IF\Ifman\_cv\_F.doc  
Rev. F  
July 26, 1999

## **Disclaimer**

Every attempt has been made to make this material complete, accurate, and up-to-date. Users are cautioned, however, that Ortel Corporation reserves the right to make changes without notice and shall not be responsible for any damages, including consequential, caused by reliance on the material presented, including, but not limited to, typographical, arithmetical, or listing errors.

## **Copyright Information**

© 1999 by Ortel Corporation

Ortel Corporation  
Alhambra, California, 91803, USA  
[www.ortel.com](http://www.ortel.com)

## WARNINGS, CAUTIONS, AND GENERAL NOTES

### Safety Considerations

When installing or using this product, observe all safety precautions during handling and operation. Failure to comply with the following general safety precautions and with specific precautions described elsewhere in this manual violates the safety standards of the design, manufacture, and intended use of this product. Ortel Corporation assumes no liability for the customer's failure to comply with these precautions.

### CAUTION

**Calls attention to a procedure or practice which, if ignored, may result in damage to the system or system component. Do not perform any procedure preceded by a CAUTION until the described conditions are fully understood and met.**

### Electrostatic Sensitivity

ESD = Electrostatic Sensitive Device

Observe electrostatic precautionary procedures.

Semiconductor laser transmitters and receivers provide highly reliable performance when operated in conformity with their intended design. However, a semiconductor laser may be damaged by an electrostatic charge inadvertently imposed by careless handling.

Static electricity can be conducted to the laser or photodiode chip from the center pin of the RF connector, and through the DC connector pins. When unpacking and otherwise handling the transmitter or receiver, follow ESD precautionary procedures including use of grounded wrist straps, grounded workbench surfaces, and grounded floor mats.

Susceptibility to electrostatic discharge is greatly reduced after the transmitter or receiver has been installed in an operational circuit.

### If You Need Help

If you need additional help in installing or using the system, need additional copies of this manual, or have questions about system options, please call Ortel's Sales Department.

## **Service**

Do not attempt to modify or service any part of the system other than in accordance with procedures outlined in this Operator's Manual. If the system does not meet its warranted specifications, or if a problem is encountered that requires service, return the apparently faulty plug-in or assembly to Ortel for evaluation in accordance with Ortel's warranty policy.

When returning a plug-in or assembly for service, include the following information: Owner, Model Number, Serial Number, Return Authorization Number (obtained in advance from Ortel Corporation's Customer Service Department), service required and/or a description of the problem encountered.

## **Warranty and Repair Policy**

The Ortel Corporation Quality Plan includes product test and inspection operations to verify the quality and reliability of our products.

Ortel uses every reasonable precaution to ensure that every device meets published electrical, optical, and mechanical specifications prior to shipment. Customers are asked to advise their incoming inspection, assembly, and test personnel as to the precautions required in handling and testing ESD sensitive opto-electronic components.

These products are covered by the following warranties:

### **1. General Warranty**

Ortel warrants to the original purchaser all standard products sold by Ortel to be free of defects in material and workmanship for one (1) year from date of shipment from Ortel. During the warranty period, Ortel's obligation, at our option, is limited to repair or replacement of any product that Ortel proves to be defective. This warranty does not apply to any product which has been subject to alteration, abuse, improper installation or application, accident, electrical or environmental over-stress, negligence in use, storage, transportation or handling.

### **2. Specific Product Warranty Instructions**

All Ortel products are manufactured to high quality standards and are warranted against defects in workmanship, materials and construction, and to no further extent. Any claim for repair or replacement of a device found to be defective on incoming inspection by a customer must be made within 30 days of receipt of the shipment, or within 30 days of discovery of a defect within the warranty period.

This warranty is the only warranty made by Ortel and is in lieu of all other warranties, expressed or implied, except as to title, and can be amended only by a written instrument signed by an officer of Ortel. Ortel sales agents or representatives are not authorized to make commitments on warranty returns.

In the event that it is necessary to return any product against the above warranty, the following procedure shall be followed:

- a. Return authorization shall be received from the Ortel Sales Department prior to returning any device. Advise the Ortel Sales Department of the model, serial number, and the discrepancy. The device shall then be forwarded to Ortel, transportation prepaid. Devices returned freight collect or without authorization may not be accepted.
- b. Prior to repair, Ortel Sales will advise the customer of Ortel test results and will advise the customer of any charges for repair (usually for customer caused problems or out-of-warranty conditions).

If returned devices meet full specifications and do not require repair, or if non-warranty repairs are not authorized by the customer, the device may be subject to a standard evaluation charge. Customer approval for the repair and any associated costs will be the authority to begin the repair at Ortel. Customer approval is also necessary for any removal of certain parts, such as connectors, which may be necessary for Ortel testing or repair.

- c. Repaired products are warranted for the balance of the original warranty period, or at least 90 days from date of shipment.

### 3. **Limitations of Liabilities**

Ortel's liability on any claim of any kind, including negligence, for any loss or damage arising from, connected with, or resulting from the purchase order, contract, or quotation, or from the performance or breach thereof, or from the design, manufacture, sale, delivery, installation, inspection, operation or use of any equipment covered by or furnished under this contract, shall in no case exceed the purchase price of the device which gives rise to the claim.

**EXCEPT AS EXPRESSLY PROVIDED HEREIN, ORTEL MAKES NO WARRANTY OF ANY KIND, EXPRESSED OR IMPLIED, WITH RESPECT TO ANY GOODS, PARTS AND SERVICES PROVIDED IN CONNECTION WITH THIS AGREEMENT INCLUDING, BUT NOT LIMITED TO, THE IMPLIED WARRANTIES OF MERCHANTABILITY AND FITNESS FOR A PARTICULAR PURPOSE. ORTEL SHALL NOT BE LIABLE FOR ANY OTHER DAMAGE INCLUDING, BUT NOT LIMITED TO, INDIRECT, SPECIAL OR CONSEQUENTIAL DAMAGES ARISING OUT OF OR IN CONNECTION WITH FURNISHING OF GOODS, PARTS AND SERVICE HEREUNDER, OR THE PERFORMANCE, USE OF, OR INABILITY TO USE THE GOODS, PARTS AND SERVICE.**

Ortel will not be responsible for loss of output or reduced output of opto-electronic devices if the customer performs chip mounting, ribbon bonding, wire bonding, fiber coupling, fiber connectorization, or similar operations. These processes are critical and may damage the device or may affect the device's output or the fiber output.

Ortel test reports or data indicating mean-time-to-failure, mean-time-between-failure, or other reliability data are design guides and are not intended to imply that individual products or samples of products will achieve the same results. These numbers are to be used as management and

engineering tools, and are not necessarily indicative of expected field operation. These numbers assume a mature design, good parts, and no degradation of reliability due to manufacturing procedures and processes.

Ortel is not liable for normal laser output degradation or fiber coupling efficiency degradation over the life of the device.

## DANGER

This fiberoptic laser transmitter contains a class IIIb laser product as defined by the U.S. Department of Health and Human Services, Public Health Service, Food and Drug Administration. This laser product complies with 21 CFR, Chapter I, Subchapter J of the DHEW standards under the Radiation Control for Health and Safety Act of 1968. The laser module certification label is located on the top of the transmitter enclosure and it also shows the required **DANGER** warning logotype (as shown below).

The Ortel laser products are used in optical fiber communications systems for radio frequency and microwave frequency analog fiberoptic links. In normal operation, these systems are fully enclosed and fully shielded by the hermetically sealed laser metal package. Laser bias current is limited by the internal control circuitry. The transmitters are coupled to glass fiber and have 1300 nm optical output wavelength with typically 0.5 to 7.0mW output depending on the model. The optical radiation is confined to the fiber core. Under these conditions, there is no accessible laser emission and hence no hazard to safety or health. Variations in the different models reflect the bandwidth, optical output, noise, and distortion of the laser.

Since there is no human access to the laser output during system operation, no special operator precautions are necessary when fiber is connected to the transmitter and receiver. During installation, service, or maintenance, the service technician is warned, however, to **take precautions which include not looking directly into the fiber connector or the fiber which is connected to the fiber connector before it is connected to the fiberoptic receiver. The light emitted from the fiberoptic connector or any fiber connected to the connector is invisible and may be harmful to the human eye. Use either an infrared viewer or fluorescent screen for optical output verification. All handling precautions as outlined by the FDA and ANSI Z136.2 and other authorities of class IIIb lasers must be observed.**

**Do not attempt to modify or to service the laser transmitter.** Return it to Ortel Corporation for service and repair. Contact the Ortel Corporation Customer Service Department for a return authorization if service is necessary.



## TABLE OF CONTENTS

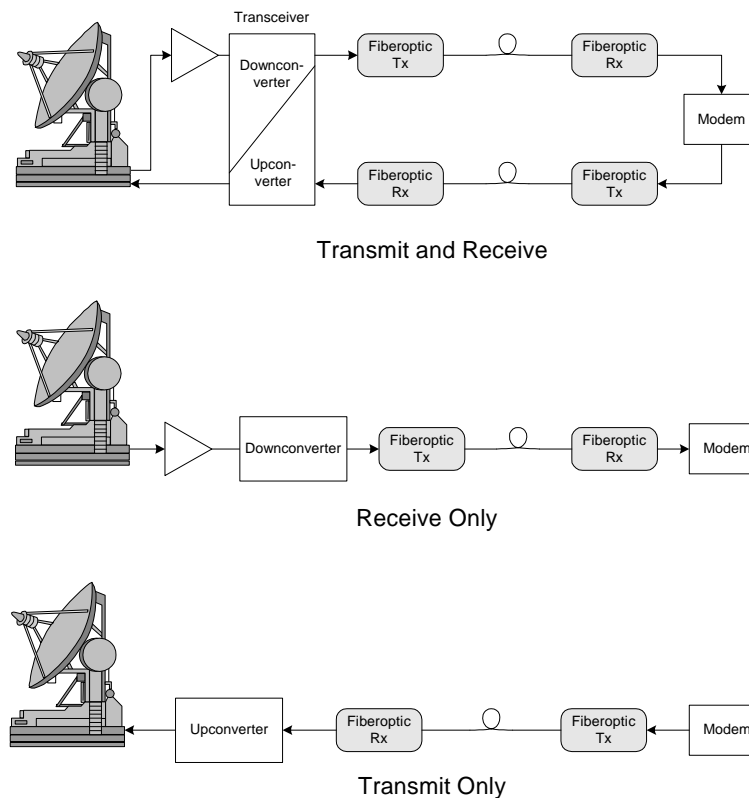
<b>CHAPTER 1 TYPICAL APPLICATIONS &amp; GENERAL FEATURES .....</b>	<b>2</b>
1.1 FIBEROPTIC LINK.....	3
1.2 OPTIONAL FEATURES .....	3
<b>CHAPTER 2 RF PERFORMANCE .....</b>	<b>5</b>
2.1 RF AND ENVIRONMENTAL SPECIFICATIONS .....	5
<b>CHAPTER 3 DC POWERING, MONITORS, AND ALARMS .....</b>	<b>6</b>
3.1 DC ELECTRICAL POWER REQUIREMENTS.....	6
3.2 DC INPUTS/OUTPUTS .....	6
3.2.1 Flange-mount Module.....	6
3.2.2 10K Plug-in Module.....	8
3.2.2.1 Model 10990A chassis & power supply monitoring and connections .....	9
<b>CHAPTER 4 FIBEROPTIC COMPONENTS .....</b>	<b>10</b>
4.1 OPTICAL SPECIFICATIONS.....	10
4.2 OPTICAL FIBER BASICS .....	10
4.3 OPTICAL FIBER .....	11
4.4 OPTICAL CONNECTORS.....	11
4.5 DETECTING OPTICAL POWER.....	13
<b>CHAPTER 5 INSTALLATION .....</b>	<b>15</b>
5.1 CHECKLIST FOR UNPACKING CARTONS .....	15
5.2 INSTALLING FLANGE-MOUNT MODULES IN THE OUTDOOR NEMA ENCLOSURE .....	16
5.3 INSTALLING FLANGE-MOUNT MODULES IN THE 1U RACK MOUNT CHASSIS .....	17
5.4 INSTALLING 10K PLUG-IN STYLE MODULES IN THE 3U RACK MOUNT CHASSIS .....	20
<b>CHAPTER 6 OPTIMIZING RF PERFORMANCE.....</b>	<b>21</b>
6.1 LINK GAIN.....	21
6.2 COMMON LINK PERFORMANCE PARAMETERS .....	21
<b>CHAPTER 7 TROUBLESHOOTING AND MAINTENANCE .....</b>	<b>23</b>
7.1 LOW OR NONEXISTENT RF GAIN .....	23
7.2 HIGH NOISE OR INTERMODULATION DISTORTION .....	23
7.3 LOW OPTICAL POWER AT THE RECEIVER .....	23
7.4 DC CIRCUIT VERIFICATION .....	24
7.5 FUSE REPLACEMENT .....	24

## Chapter 1 Typical Applications & General Features

The 3120A/10357A series fiberoptic transmitter and the 4120A/10457A series fiberoptic receiver, connected with a single mode fiberoptic cable, make up an interfacility link (IFL) designed for use in satellite earth terminals. The 3120A/10357A, 4120A/10457A link covers the frequency range 10MHz to 200MHz and replaces the traditional coaxial cable link between the earth station's outdoor unit at the antenna and the indoor unit (receiver, modem, etc.). The specifications and options are designed to satisfy the requirements for use in earth terminals for:

- VSAT - One Way
- VSAT - Two Way
- In-building IF extension

Refer to the block diagrams in Figure 1-1 for examples of these typical applications.



**Figure 1-1** Typical applications of the Ortel IF-band IFL.

Both the 3120A and the 4120A models are flange-mount modules which are designed for mounting in outdoor NEMA box enclosures, in a 1U high, 19 inch rack mount chassis (here, "U" indicates rack unit which, in a standard 19" rack, is equivalent to  $\approx 1.75$ "), or in other small spaces. For DC powering, these units take bias voltage via wire leads. In an outdoor environment the wire leads should be connected using silicone-filled wire nuts for waterproofing and the RF and optical connectors should be potted with RTV (the optical connectors are *not* to be potted with silicone as it can harm optical fiber).

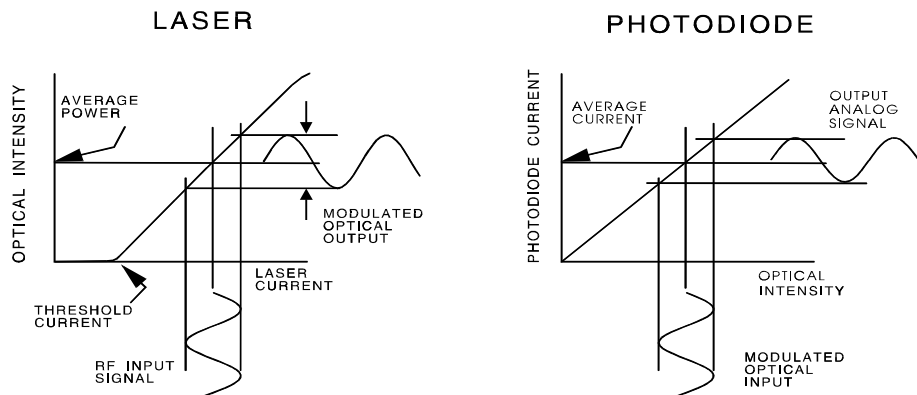
The model 10357A and 10457A units are designed specifically to mount in Ortel's System 10000 rack mount chassis. This chassis (Model 10990A) is a 3U high 19" rack mountable unit which can hold up to 8 plug-in modules. It is intended for indoor applications and can be powered easily from standard AC inputs via the Model 10901 power supply.

## 1.1 Fiberoptic Link

At the heart of the fiberoptic link is a wideband, uncooled, directly modulated laser transmitting an optical signal to a photodiode receiver. The laser is biased with a DC current, on top of which is modulated the RF signal from the satcom link. This produces an intensity modulation of the optical output, as demonstrated in Figure 1-2. The modulated light from the laser is then coupled into the fiber. At the other end of the fiber, a semiconductor PIN photodiode converts this optical signal into an electrical current which is amplified and delivered to the output load. The resulting signal is a recovered copy of the original RF signal.

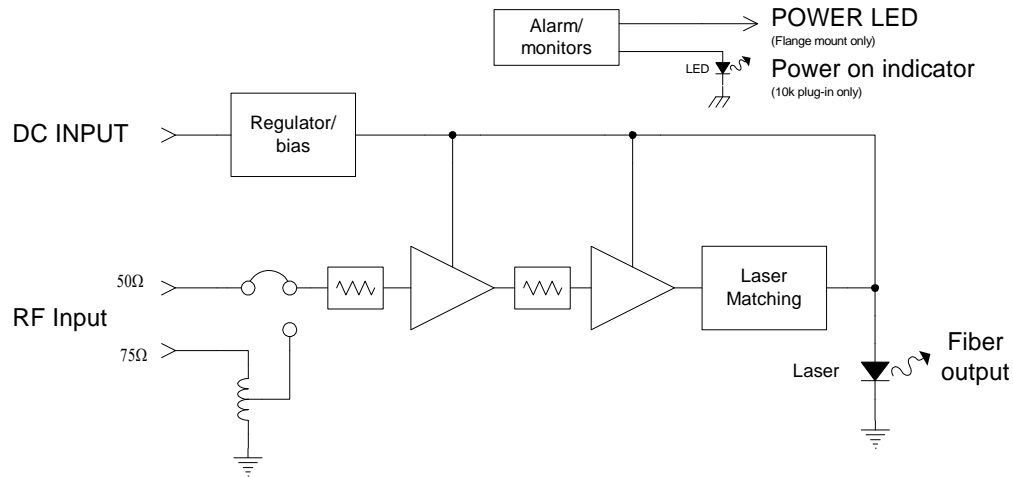
## 1.2 Optional Features

In addition to the primary packaging and frequency range features, other options are available, as listed in Table 1-2 and shown in Figures 1-3 and 1-4. The readily available options are module gain and characteristic impedance. For example, the amount of amplification in the standard transmitter and receiver was designed to provide an overall RF link gain of  $\geq 0$ dB when implemented with an optical loss of 1dB; and to provide roughly equivalent S/N and C/I when the total input power is near -27dBm. However, for those applications with higher power input signals, or where a different link gain is required, option 102 may be used (as detailed in chapter 2.)

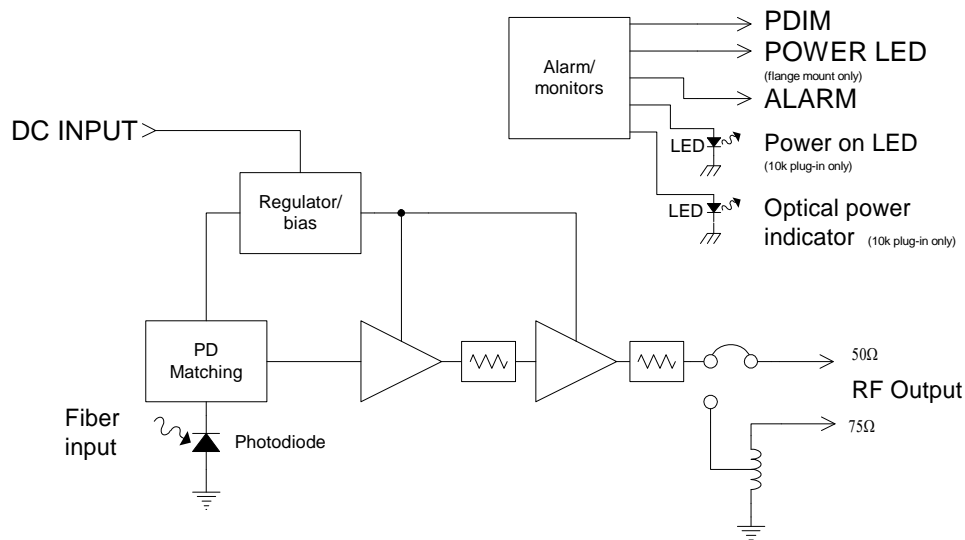


**Figure 1-2** Heart of a fiberoptic link—conversion of electrical and optical RF signals.

Table 1-1 IF-BAND OPTIONS				
Option Designator	Option Availability		Option Description	Standard Configuration
	Flange	Plug-in		
101	X	X	50Ω characteristic impedance with BNC female connector.	75Ω BNC connector, female.
102	X	X	For higher signal input. Tx: Single stage of amplification. Rx: Two stages of amplification.	Tx: Two stages of amplification. Rx: Single stage of amplification.



**Figure 1-3** IF-band transmitter block diagram. Standard gain configuration is shown. Low gain model (option 102) has a single stage pre-amplifier.



**Figure 1-4** IF-band receiver block diagram. High gain (option 102) configuration is shown. Standard gain model has a single stage pre-amplifier.

## Chapter 2 RF Performance.

Since the fiberoptic link has an analog RF input and output, its performance can be specified and analyzed like any RF component, with parameters such as noise figure, third order intercept (IP3), VSWR, etc. The main caveat is that the optical loss and the specific choice of transmitter and receiver must be known. In the tables below, the worst case RF performance has been specified for the case of 1dB of optical loss. Some units may have gain much higher than that listed below.

If the optical loss is greater than 1dB, the RF gain will drop 2dB for each additional 1dB of optical loss and the noise figure will begin to degrade. (For example, a standard gain link with 2dB of optical loss would have an RF gain of  $\geq -2$ dB, while the same link with 1dB optical loss would have  $\geq 0$ dB.) The exact amount of noise degradation will depend on the optical back reflections and length of the fiber, but as a rough rule of thumb, the noise will stay fairly close to the value for 1dB optical loss up to about 3-4dB of optical loss, and then begin degrading about 2dB for each additional 1dB of optical loss. For high optical losses, optical back-reflections also must be minimized to avoid degrading the C/I. This generally means that these IF-band transmitters will work well with quality optical splitters and connectors, but may suffer some RF degradation when used with fibers with lengths upwards of several kilometers. Chapter 4 describes in greater detail the use of fiberoptic components with these links.

### 2.1 RF and Environmental Specifications

When optimizing the RF performance, the main concern involves setting the input RF signal level. A detailed analysis may be carried out using Table 2-2 below, or as another rough rule of thumb, the optimal total RF power into the transmitter should be near  $-27$ dBm for a standard gain transmitter and  $-10$ dBm for a low gain unit. Due to the dynamic range of these links, the RF power can deviate some from this optimal level and still provide good results. For specific examples of optimizing links, see Chapter 6.

Table 2-1 RF SPECIFICATIONS					
For complete link of Tx, Rx, 1dB optical loss, & >60dB optical return loss					
Tx gain option		Std.	-102 (low)	Std.	-102 (low)
Rx gain option		Std.	-102 (high)	-102 (high)	Std.
Link gain (at 25°C), min.		0dB	0dB	+15.0dB	-15.0dB
Amplitude flatness	full band	$\pm 0.5$ dB	$\pm 0.5$ dB	$\pm 0.5$ dB	$\pm 0.5$ dB
	any 40MHz	$\pm 0.25$ dB	$\pm 0.25$ dB	$\pm 0.25$ dB	$\pm 0.25$ dB
Noise figure, max.		28dB	43dB	28dB	43dB
Input IP3, min.	(Tx to -20°C)	0dBm	+5dBm	-10dBm	+15dBm
Input 1dB compression (typical)	(Tx to -20°C)	$\geq -10$ dBm	$\geq -5$ dBm	$\geq -20$ dBm	$\geq +5$ dBm
Gain vs. temperature (typical)	Tx	0.07dB/°C	0.06dB/°C	0.07dB/°C	0.06dB/°C
	Rx	0.06dB/°C	0.07dB/°C	0.07dB/°C	0.06dB/°C
VSWR (input/output)		1.5 : 1	1.5 : 1	1.5 : 1	1.5 : 1
Maximum RF input (Tx)		-8dBm	+7dBm	-8dBm	+7dBm
In/out impedance		75Ω BNC, female (50Ω BNC, option 101)			

Table 2-2 ENVIRONMENTAL SPECIFICATIONS			
	Flange-mount		10K style Plug-in
	Transmitter	Receiver	
Operating Temperature	-20 to +60°C	-40 to +60°C	0 to +50°C
Storage Temperature	-45 to +85°C		-45 to +85°C

## Chapter 3 DC Powering, Monitors, and Alarms

### 3.1 DC Electrical Power Requirements

The fiberoptic transmitters (Tx) and receivers (Rx) described in this manual require a DC bias input of +12V to +24V and a current as specified in Table 3-1.

Table 3-1 MAXIMUM CURRENT REQUIREMENTS				
Input voltage	12V	15V*	18V	24V
Transmitter	170mA	135mA	115mA	85mA
Receiver	150mA	120mA	100mA	70mA

\*+15V may be provided by Ortel Model 10901A or 10901B power supplies.

- Ripple & Noise Requirement: 20mV<sub>p-p</sub> below 100kHz, 100mV<sub>p-p</sub> above 100kHz

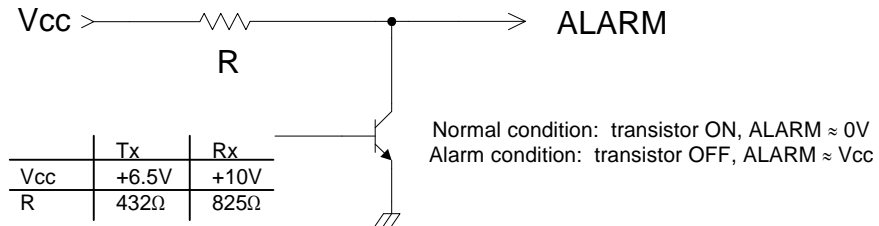
Table 3-2 MAX. CURRENT REQUIREMENTS		
Product	Standard gain	Gain option -102
3120A, 10357A (Tx)	250mA	350mA
4120A, 10457A (Rx)	250mA	150mA

### 3.2 DC Inputs/Outputs

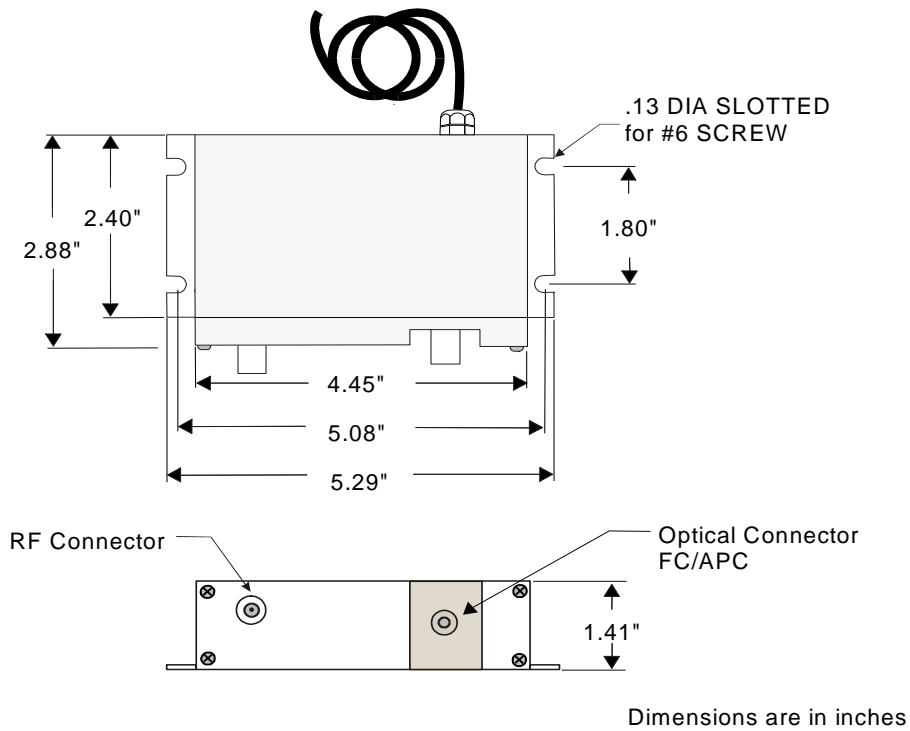
#### 3.2.1 Flange-mount Module

The flange-mount packages possess 5 flying leads which carry the DC input voltage and the alarms and status monitors listed in Table 3-3 below. Any unused wires should be wrapped with electrical tape to avoid short circuits. The Ortel provided 1U high rack mount chassis or NEMA-style enclosure both include terminal strips for these leads. Chapter 5 contains detailed procedures for installing units in these boxes.

Table 3-3 FLANGE-MOUNT DC LEADS				
Lead Color	Tx, IF-band, Flange-mount		Rx, IF-band, Flange-mount	
	Signal	Description	Signal	Description
Red	DC INPUT	+12-24VDC	DC INPUT	12-24VDC
Brown	GND	DC return.	ALARM	Low received optical power.
Black	GND	DC return.	GND	DC return.
Orange	POWER LED	Output capable of driving an LED for remote monitoring purposes. Indicates presence of regulated DC voltage in the unit.	POWER LED	Output capable of driving an LED for remote monitoring purposes. Indicates presence of regulated DC voltage in the unit.
Yellow	GND	DC return.	PDIM	Photodiode current monitor.



**Figure 3-1** ALARM circuit for both flange-mount and plug-in style IF-band receivers. Transistor switches at approximately 0.1mW received optical power.



**Figure 3-2** Flange-mount package dimensions.

### 3.2.2 10K Plug-in Module

Plug-in style units may be used with an Ortel rack mount chassis (model 10990A), main power supply (model 10901A), and optional back-up power supply (model 10901B). Figure 3-3 shows an outline drawing of a plug-in receiver module (the transmitter is nearly identical). The fiberoptic transmitter or receiver can be installed into any of eight designated slots in the chassis. D-connectors on the rear panel of the plug-ins automatically engage blind-mate D-connectors on the chassis back plane which are wired to the power supplies. The only remaining connections to be made are to the RF and optical connectors. Transmitters and receivers may be inserted with the power supply turned on or off. Refer to Table 3-4 for a listing of the input and output signals for this unit.

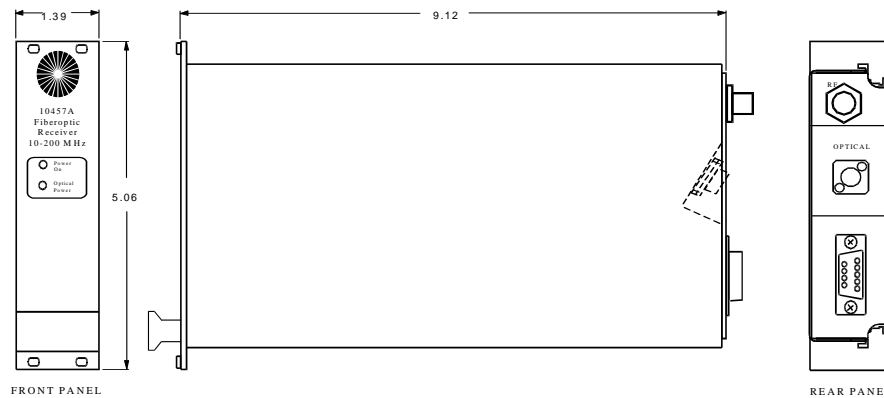


Figure 3-3 Plug-in package dimensions.

The status of the Tx and Rx plug-ins and power supplies can be monitored either from the front panel LEDs or from back panel DC connectors. Both the Tx and Rx have a “Power On” LED, while the Rx also has an “Optical Power” LED which is illuminated if the optical power into the receiver is greater than approximately 0.1mW. The 8 transmitter/receiver slots of the 10990A chassis each have a 5 pin connector (P11-P18, facing the rear) which provides external access to the various status and alarm signals from the transmitters and receivers.

Tx/Rx D-sub Pin #	Back Panel P20	Back Panel P11-P18	Transmitter		Receiver	
			Signal	Description	Signal	Description
1	2 (+15VDC)		DC INPUT	+15VDC	DC INPUT	+15VDC
2	1 (+5V)		nc	nc	nc	nc
3	3 (-15V)		nc	nc	nc	nc
4	4 (GND)		GND		GND	
5		1	GND		GND	
6		2	nc	nc	PDIM	Photodiode current monitor. 1V/mA
7		3	nc	nc	ALARM	Low optical power alarm. 0V/low Z if $P_{\text{optical}} > 0.1\text{mW}$ . +10V/high Z if $P_{\text{optical}} < 0.1\text{mW}$ .
8		4	nc	nc	nc	nc
9		5	nc	nc	nc	nc

nc = No Connection

### 3.2.2.1. Model 10990A chassis & power supply monitoring and connections

The status of the Model 10901 power supply can be monitored from a pair of relays wired to a 9 pin in-line connector (P19) on the 3U chassis. The pinouts are of the connector are described in Table 3-5. Another connector (P20) connects directly to the power supply in the “main” slot in the chassis, which is the farthest left slot when viewed from the back. This connector allows direct monitoring of the DC power voltages of the main power supply. This connector can also be used for powering the chassis via an external source (i.e. without a chassis-mounted 10901A or B power supply). The main power supply slot and P20 connect to the plug-ins through a set of diodes which allows for the power supply redundancy, hence neither the back-up power supply voltages nor the actual voltage at the plug-in can be monitored via P20 (voltage drops across the diodes must be accounted for).

<b>Table 3-5 POWER SUPPLY STATUS MONITORING VIA THE 10990A CHASSIS CONNECTOR (P19)</b>					
Pin	Description	Main normal*	Main alarm*	Aux. normal*	Aux. alarm*
1	nc	--	--	--	--
2	nc	--	--	--	--
3	Aux. Status (normally closed)	--	--	low Z to center tap (relay closed)	high Z to center tap (relay open)
4	Aux. Status (center tap)	--	--	center tap	center tap
5	Aux. Status (normally open)	--	--	high Z to center tap (relay open)	low Z to center tap (relay closed)
6	Main Status (center tap)	center tap	center tap	--	--
7	Main Status (normally closed)	low Z to center tap (relay closed)	high Z to center tap (relay open)	--	--
8	Main Status (normally open)	high Z to center tap (relay open)	low Z to center tap (relay closed)	--	--
9	Ground	--	--	--	--

\* Power supply status is determined by monitoring the power supply's +5V output only. The “Main” slot is the farthest left slot when viewed from the back.

<b>Table 3-6 10990A CHASSIS MATING CONNECTORS AND PINS</b>		
Back Plane Connector	Mating Connector	Crimp Pins
P11-P18	Molex P/N 22-01-2057	Molex P/N 08-50-0114
P19	Molex P/N 22-01-2097	Molex P/N 08-50-0114
P20	Molex P/N 09-50-3031	Molex P/N 08-50-0108

## Chapter 4 Fiberoptic Components

### 4.1 Optical Specifications

The information included in Table 4-1 describes the optical parameters of the transmitter and receiver.

Table 4-1 OPTICAL SPECIFICATIONS (at +25°C)	
Transmitter	
Wavelength	1310 ± 30 nm
Power	1.20 ± 0.4mW
Laser DC modulation gain	≥ 0.02W/A
Receiver	
Wavelength	1280-1550nm
Photodiode DC responsivity	≥ 0.85A/W @ 1310nm
Fiber	Singlemode, 9/125 (Corning SMF-28 or equivalent)
Connector	FC/APC "tight fit" (Type 'R' per IEC 1754-10-1) ≥ 60dB optical return loss

### 4.2 Optical Fiber Basics

Light traveling in an optical fiber uses the principle of *total internal reflection*. Generally, when light is incident on a boundary between two transparent media of different optical densities, there is a refracted and a reflected ray. However, if the incident medium is more optically dense (higher index of refraction), there is an angle of incidence below which there is no refracted ray; all the light is reflected. In optical fiber, the central core has a slightly higher index of refraction than the cladding (see Figure 4-1). Also, the core is small enough in diameter that all light that can be transmitted through the fiber will always be traveling in a path where all angles of incidence are such that the light is totally reflected.

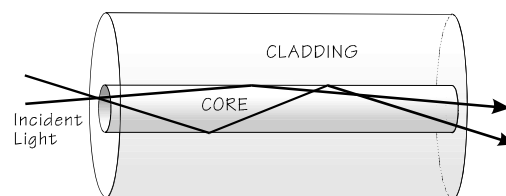


Figure 4-1 Light propagation in a step indexed fiber

Multimode fiber has a core large enough that there may be many spatial modes in the fiber. This is analogous to sending an 18 GHz RF signal through waveguide designed for 200 MHz. There will be a lot of modal dispersion that severely limits the bandwidth of modulated signals and makes the transmission sensitive to the movement and bending of the fiber. *Singlemode* fiber has a core diameter small enough that only one mode is passed. This minimizes dispersion and makes the fiber's transmission properties insensitive to movement. For this reason, **only singlemode fiber should be used with Ortel links.**

### 4.3 Optical Fiber

Ortel transmitters and receivers are designed for use with singlemode optical fiber (with the dispersion minimum at 1310 nm). This fiber accounts for the majority of the fiber installed in the world today. While many styles exist for the outer jackets and cables, the fundamental glass portion of the fiber is consistently 125 microns in total diameter, with the inner 8-10 microns being the core which actually contains the light. With such a small core, cleanliness and care of bare fiber is critical. This is why most singlemode fibers are covered with several layers of protection, the first of which is a 250 micron coating. After that, indoor cables have a 900 micron plastic "tight buffer", while many outdoor cables use a "loose tube" instead in which the fiber floats in a petroleum-based jelly inside a durable outer shell. Other cable designs include strength members, armor plating, and often multiple fibers. As an example, 5/8 inch diameter cable assemblies are available containing as many as 96 fibers. The exact cable style will depend on the application.

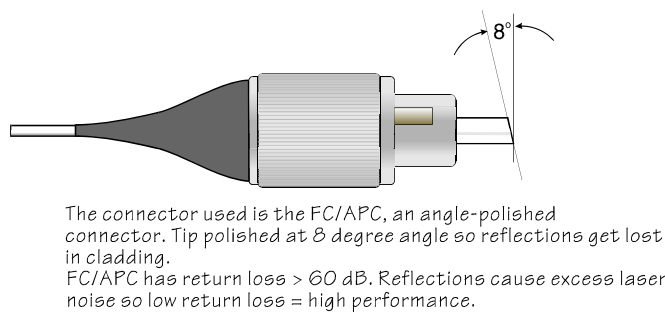
Regardless of the type of cable chosen, several considerations are universal, with perhaps the most critical being bend radius. Like many types of RF cables, when an optical fiber is bent tighter than roughly a 1 inch (25 mm) radius, the light will escape thus decreasing the RF gain of the link. Much tighter than 1 inch also may permanently damage some fibers. Thus when storing or installing fiberoptic cable it should be wound and bent in loose coils or turns. On the convenient side, optical fiber is immune to all electrical cross-talk, therefore optical cables can be installed next to power and communication lines with no concern of signal degradation.

Finally, the fiber also must be singlemode, not multimode. Multimode fiber does not have sufficient bandwidth nor gain stability for the applications serviced by Ortel links.

### 4.4 Optical Connectors

There are many optical connectors on the market. For high performance, high frequency RF applications, the connector must be for singlemode fiber and be repeatable, low loss and, most importantly, have a low optical return loss. Connectors with no return loss specification are for low speed digital and analog applications. Return loss is important because optical reflections can degrade noise and linearity performance.

*Connector styles.* The Ortel connector of choice is the FC/APC, as indicated in Figure 4-2. In particular, the connector used is the FC/APC "tight fit", compatible with the Seikoh Giken connector. It has proved to be reliable



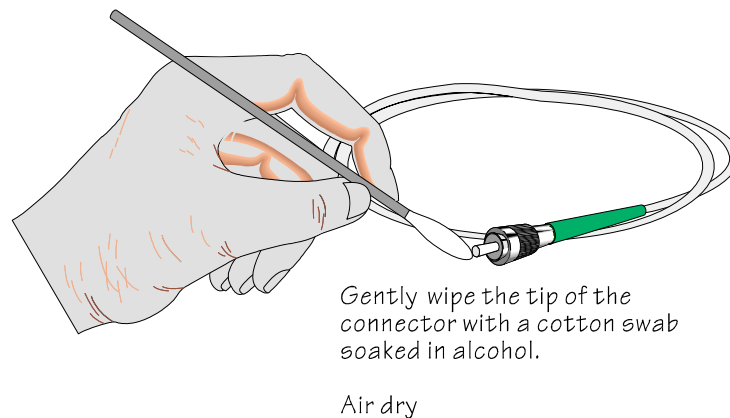
**Figure 4-2** FC/APC style optical connector.

and repeatable, and most important, has very low backreflections of < -60dB. There are a number of manufacturers who make connectors compatible with this connector; e.g., Seikoh Giken, Alcoa Fujikura and the Molex "Tight Fit". Note that the Diamond FC/APC has a larger "key" and will not fit in the slot on the bulkhead optical connector. If in doubt on the connector style, the width of the mating key can be measured. The tight fit style has a key width of 2.00 mm (+.02, -.03 mm) while the wider styles typically are 2.14 mm.

Two other common styles of connectors include the ST, which is a bayonet style connector analogous to an RF BNC connector, and the SC, which is a "snap together" connector. The FC style has a threaded sleeve for making reliable mechanical connections. In all these cases the connectors themselves are sexless, with connections being made using adapters that simply guide the tips of two common connectors together to make a continuous optical path. While only FC/APC connectors can be mated directly with the Ortel transmitters and receivers, other connector styles or optical splices may be used at patch panels provided the optical backreflections are kept low. The best way to insure this is to use connectors with an 8 degree APC style polish or splices with optical reflections comparable to that of APC connectors. Although no permanent damage to the transmitters or receivers occur, high optical reflections can degrade the gain, noise, and linearity during operation.

*Cleaning.* Fiberoptic connectors on cable that come pre-terminated should be clean and capped, so one can usually simply remove the cap and make the connection without cleaning the connector. But if there is any doubt, it is good practice to clean the optical connectors before making the connection. Once the connection is made, there is no need to periodically clean the connector as long as it remains connected. Additionally, the laser and photodiode of the transmitter and receiver never require cleaning, although it is recommended to keep them covered when not in use.

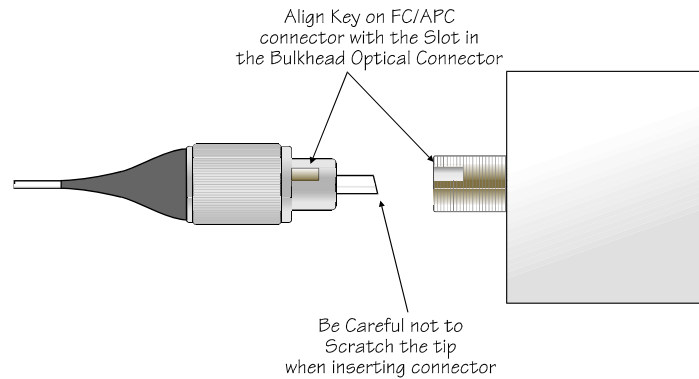
When handling or cleaning, remember that the light is emitted from an aperture only 9  $\mu\text{m}$  in diameter, so even oils from your fingertips or a small scratch can easily cause interference. The concern is not just optical loss, but also optical reflections, which can affect laser noise and distortion. To clean, moisten a cotton swab in alcohol



**Figure 4-3** Cleaning optical connectors.

and gently wipe the tip of the connector ferrule several times. Allow to air dry. Refer to Figure 4-3.

*Connecting.* Once the connector is clean, bring it up to the bulkhead optical connector on the laser or photodiode module. Note that the connector has a "key" on the side of its housing that must fit into the slot in the bulkhead connector, as shown in Figure 4-4. Once these are aligned, carefully push the fiber connector into the bulkhead connector so the key fits into the slot. (Not having the key properly aligned in the slot is a common problem when using such optical connectors.) Next, push the threaded outer shell of the connector onto the bulkhead so that the threads engage. *The connector should be fastened finger tight only. Overtightening can damage the laser or photodiode.*



**Figure 4-4** Inserting FC-APC connectors.

## 4.5 Detecting Optical Power

The light from the transmitter is infrared and invisible to the human eye, hence some indirect method is needed to detect it. The cheapest and easiest way to determine if the transmitter is emitting light is to direct the laser or a fiber connector onto an infrared detection card (available, for example, from Fiber Instrument Sales, Inc., Part #F1-4103 for approximately \$10. Orsinsky, New York, USA, phone: 315-736-2206). Such cards glow a reddish color with an intensity and shape corresponding to the infrared light. These cards are ideal for telling if a laser is on or if a fiber has light in it.



*The light emitted from the fiberoptic connector or any fiber attached to the connector is invisible and may be harmful to the human eye. Use either an infrared viewer or fluorescent screen for optical output verification.*

For a more quantitative measurement, an optical power meter with a calibrated detector can be used. (In North America, Fiber Instrument Sales, EXFO [at 418-683-0211, or [www.exfo.com](http://www.exfo.com)], Newport Corporation [at 714-253-1680, or [www.newport.com](http://www.newport.com)] and many other companies make commercially available power meters.) Additionally, the plug-in style receiver has a status monitor output, PDIM, which gives a voltage that is proportional to the DC current on the photodiode (which is, in turn, proportional to the intensity of the received optical signal). When the photodiode is illuminated with light, the DC current goes from near zero to a value which is proportional to the intensity of the light.

The following equation describes the relationship between a link's optical parameters and its corresponding RF performance.

$$G_{\text{RF, fiber}} = -20 \log (P_{\text{Tx}} / P_{\text{Rx}}) = -20 \log [(P_{\text{Tx}} \times r_{\text{Rx}}) / I_{\text{Rx}}] = 2 \times L_{\text{optical}} \quad \text{Eq. 4-1}$$

where,

$G_{\text{RF, fiber}}$  = RF gain of the optical medium  
 $P_{\text{Tx}}$  = optical power from the transmitter  
 $P_{\text{Rx}}$  = optical power at the receiver  
 $= I_{\text{Rx}} / r_{\text{Rx}}$

$I_{Rx}$  = DC current from the photodiode  
 $r_{Rx}$  = DC responsivity of the receiver  
 $L_{optical}$  = optical loss in dB between the transmitter and the receiver

It is evident that  $G_{RF}$  is the effective RF gain (or *loss*, since  $G_{RF}$  is normally  $\leq 0$ ) of the medium used to transport the optical signal from the laser transmitter to the receiver. For example, if  $P_{Tx} = P_{Rx}$  (no optical loss), then  $G_{RF} = 0$ dB.

## Chapter 5 Installation

Setting up the fiberoptic link is fairly straightforward once the fiberoptic cable is in place with the proper fiberoptic connectors. **The cable must have FC/APC “tight fit” optical connectors compatible with the Seikoh Giken connector.** There are a number of manufacturers who make connectors compatible with this connector; e.g., Seikoh Giken, Alcoa Fujikura and the Molex "Tight Fit". However, the Rifocs Diamond FC/APC has a larger "key" and will not fit in the slot on the bulkhead optical connector of your Ortel product. If in doubt on the connector style, the width of the mating key can be measured. The tight fit style has a key width of 2.00 mm (+.02, -.03 mm) while the wider styles typically are 2.14 mm. Additionally, for optimal noise and linearity performance, other connectors and splices in the system should have low optical reflections, comparable to that of APC connectors.

This guide and checklist starts by listing the contents of the shipping cartons. It is followed by instructions to install the flange mount modules in the outdoor enclosure and the 1U high rack mount chassis and the plug-in units into the 3U high rack mount chassis.

### 5.1 Checklist for Unpacking Cartons

There are four different types of cartons used for packing the fiberoptic link: (A) a small cardboard box for flange-mount modules, (B) a carton for the outdoor (NEMA) enclosure, (C) a carton for the 1U high rack mount chassis, and (D) a carton for the 3U high rack mount chassis (for plug-in modules). The fiberoptic transmitter and receiver modules must be installed in the outdoor enclosure or rack mount chassis by the user (see next section).

- A) Module Carton - for flange-mount modules
  - This carton(s) contains the flange-mount modules which are packed separately from any of the available mounting chassis.
- B) Outdoor Enclosure Carton (NEMA) - for flange-mount modules
  - One (1) Type 3R NEMA Enclosure, Ortel P/N 1260-001-001.
  - One (1) Mounting Kit. This hardware is for mounting up to two flange-mount modules inside the NEMA box, not for mounting the NEMA box itself. It includes:
    - Eight (8) #6 x 3/16 inch long Phillips style pan head screws. The back panel of the NEMA is pre-drilled and tapped for this hardware.
    - Eight (8) #6 split lock washers.
    - Two (2) wire saddles with adhesive base to be mounted inside the NEMA box on the back panel. Used for strain relief for RF and optical cables.
- C) Indoor Rack Mount Chassis Carton - for flange-mount modules
  - One (1) 1U high, 19 inch rack mount chassis with or without optional internal universal power supply.
  - One (1) AC power cord (North America version).
  - One (1) Mounting Kit. This hardware is for mounting up to four flange-mount modules inside the chassis, not for mounting the chassis itself. It includes:
    - 16 #6 flat head screws<sup>1</sup>
    - 8 #6 split lock washers<sup>2</sup>

<sup>1</sup> Applies to early versions of the 1U high chassis. Later versions come with pre-installed threaded studs, eliminating the need for the user installed mounting screws.

<sup>2</sup> Early versions of the 1U chassis utilized quantity 16 for each of the washer types and nuts.

- 8 #6 flat washers<sup>2</sup>
  - 8 #6 hex nuts<sup>2</sup>
  - 2 wire saddles with adhesive base to be mounted inside the chassis. Used for strain relief for RF and optical cables.
  - 4 resistors, 2.2k $\Omega$  (for use with older transmitter and receiver modules)
  - Two (2) Chassis Mounting Brackets. Front panel rack mounting flanges.
- D) Indoor Rack Mount Chassis Carton - for plug-in modules
- One (1) 3U high, 19 inch rack mount chassis, with or without internal power supplies.
  - Up to two (2) AC line cords (North America version), depending on power supply configuration.

## 5.2 Installing Flange-mount Modules in the Outdoor NEMA Enclosure

The outdoor enclosure available from Ortel is pre-drilled to mount one or two modules. You will need a #2 Phillips screwdriver and a medium sized flat tip screwdriver.

1. For a watertight seal, pot the optical connectors with RTV. This will be easier to do before the module is secured to the back panel of the outdoor enclosure. *Do not use silicone. Silicone outgases and, over time, will darken the fiber.* If the NEMA box alone provides enough environmental protection for the modules, skip this step.
2. Fasten the module to the back panel of the NEMA box using the #6 screws and split lock washers. The holes in the back panel are tapped. Make sure that the RF and optical connectors are pointed down.
3. The electrical connections are shown in Figure 5-1. Connect the red and black wire leads from the module to the terminal block. Make sure the red lead goes to the terminal where the +VDC wire from the remote power supply is connected. The other lead is Ground. The remaining three leads from each module may be secured to the terminal strip.

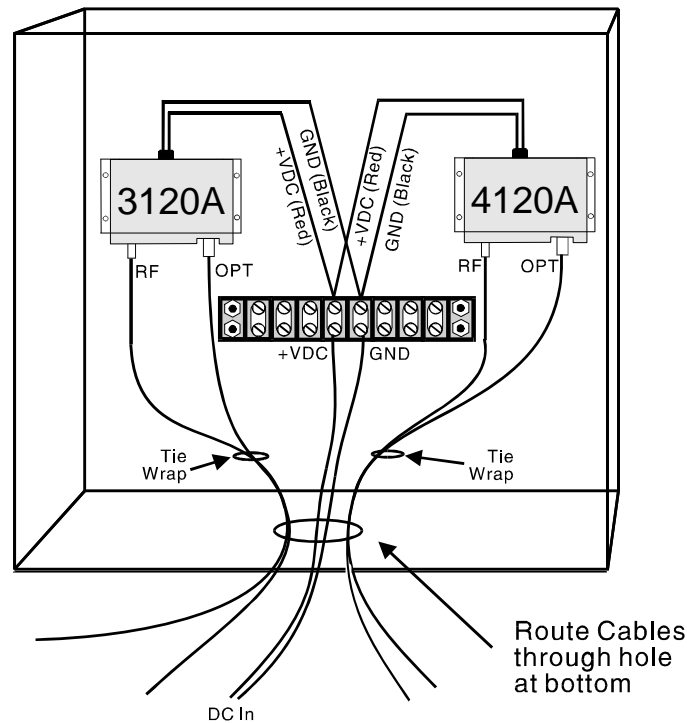
### CAUTION

**Any unused wire lead should be shielded or otherwise protected to safeguard against potentially damaging short circuits.**

4. An attenuator at the RF input to the transmitter may or may not be necessary to optimize the RF performance (see Chapters 2 ).
5. Use the adhesive-backed wire saddles and tie wraps supplied to secure the RF and optical cables to the back panel. This provides strain relief for the RF and optical connectors.
6. Replace the NEMA box front panel and secure it with the proper fasteners.

---

<sup>2</sup> Early versions of the 1U chassis utilized quantity 16 for each of the washer types and nuts.



**Figure 5-1** Installing flange-mount units in the outdoor NEMA enclosure.

### 5.3 Installing Flange-mount Modules in the 1U Rack Mount Chassis

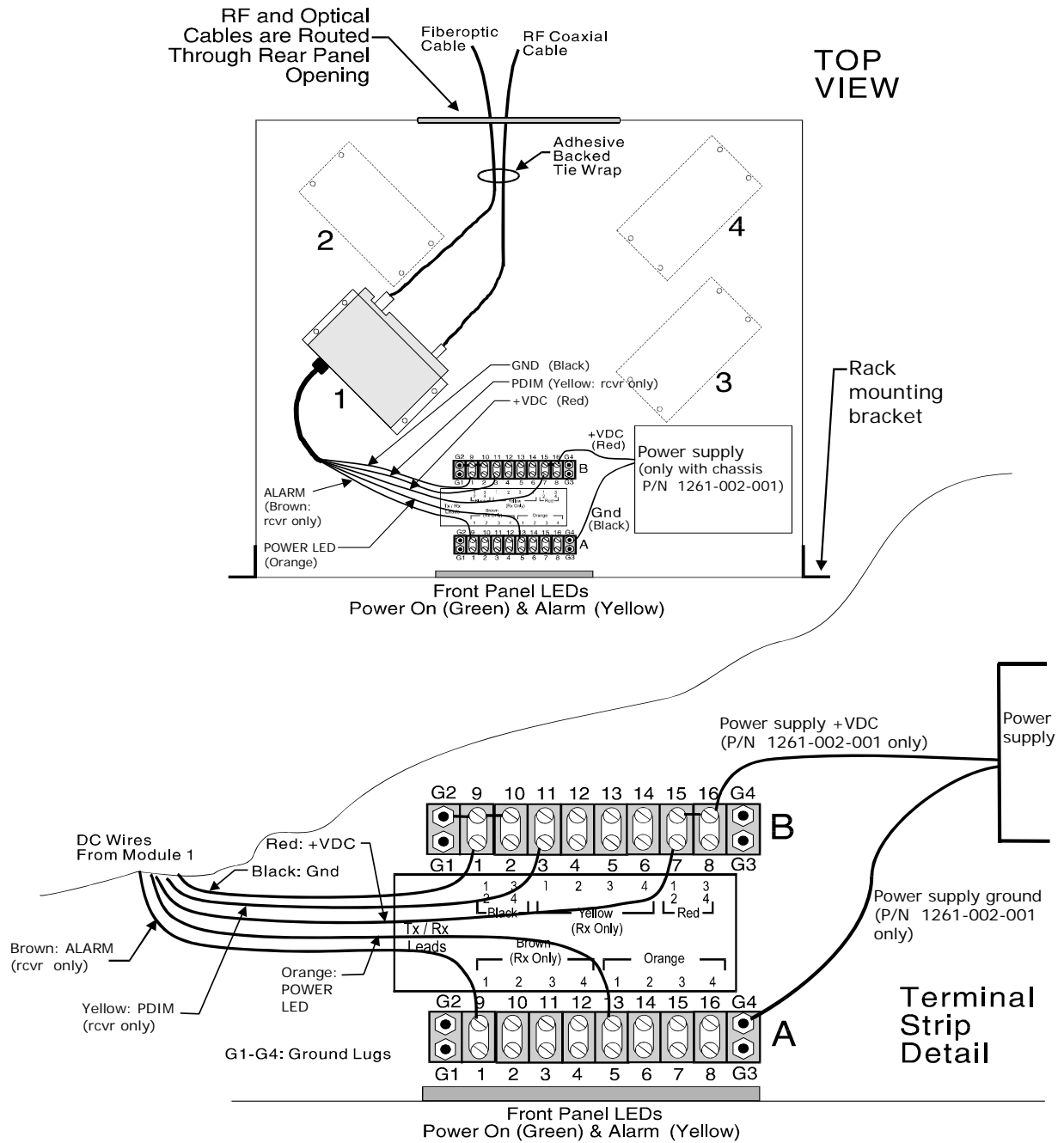
The 1U rack mount chassis available from Ortel is designed to mount up to four flange-mount modules. There are two versions: one includes a +15VDC power supply with a universal AC input and a power cord (North America version). The other does not include an internal power supply. You will need a screwdriver and a nut driver or socket wrench for the terminal screws and mounting nuts. If the chassis is to be mounted in a rack, make sure to install the front panel rack mount flanges (supplied).

1. Fasten the modules to the bottom panel using the screws<sup>3</sup>, flat washers, lock washers and nuts.
2. The DC connections are made to the terminal blocks as shown in Figure 5-2. Refer to Table 5-1 for a list of all the connections to be made.

#### **CAUTION**

**Any unused wire lead should be shielded or otherwise protected to safeguard against potentially damaging short circuits.**

<sup>3</sup> Applies to early versions of the 1U high chassis. Later versions come with pre-installed threaded studs, eliminating the need for the user installed mounting screws.



**Figure 5-2** Installing flange-mount units in the 1U chassis.

- Position the chassis in front of the rack space where it is to be mounted. Pull the fiberoptic and RF cables through from behind the rack. Route them through the opening in the chassis rear panel. Connect each input and output to the appropriate module.

**CAUTION**

**Make sure the optical connectors are finger tight only - do not over tighten or the connector may be damaged.**

- Use the adhesive-backed wire saddles and tie wraps supplied to secure the RF and optical cables to the bottom panel providing service loops where possible. This provides strain relief for the RF and optical connectors on the modules.
- Replace the top panel and attach it with the provided hardware.

**Table 5-1** Terminal Block Connections

Block A	Module # / wire color	Block B	Module # / wire color
1		1	1 / Black & 2 / Black
2		2	3 / Black & 4 / Black
3		3	1 / Yellow
4		4	2 / Yellow
5		5	3 / Yellow
6		6	4 / Yellow
7		7	1 / Red & 2 / Red
8		8	3 / Red & 4 / Red
9	1 / Brown	9	G2
10	2 / Brown	10	G2
11	3 / Brown	11	
12	4 / Brown	12	
13	1 / Orange	13	
14	2 / Orange	14	
15	3 / Orange	15	+15VDC*
16	4 / Orange	16	PS / +15VDC*
G1		G1	
G2		G2	
G3		G3	
G4	PS / Ground*	G4	

\* PS = Power Supply.

## 5.4 Installing 10k Plug-in Style Modules in the 3U Rack Mount Chassis

The 3U chassis supplied by Ortel can hold up to eight plug-in modules. Install the model 10357 transmitter and 10457 receiver plug-ins into the 10990A chassis starting with the left-most slot.

1. Carefully align the plug-in unit with the track in the desired slot of the chassis.
2. Gently slide the plug-in unit into the chassis until the rear panel sets against the backplane. The 9-pin D-connector will self align with the mating backplane connector. Do not force the unit against the backplane. If excessive resistance is felt, remove the unit and re-align it in the chassis.
3. Secure the plug-in by tightening the four corner screws on each module's front panel.

Refer to Tables 3-5 and 3-6 for connection information for the power supply status and monitoring signals available on the model 10990A 3U rack mount chassis. Table 3-4 details the back panel connections for the status monitoring features for the fiberoptic plug-in modules.

## Chapter 6 Optimizing RF Performance

This fiberoptic link has been designed to provide a transparent interfacility link for a wide range of small satellite earth terminals. The link itself has fixed gain, noise figure and linearity characteristics so its effect on earth station performance can be analyzed like any other active element in the signal path. The following sections give some guidance to optimizing the RF performance for a number of different applications. Optimizing the RF performance means setting the input RF drive level to the optimum value. If the available RF signal level is too high, an RF attenuator should be used. If the available RF level is too low for good noise performance then additional amplifiers or a higher gain fiberoptic transmitter should be used. (Some IF equipment combines both a high level 10MHz reference tone with the 70 or 140MHz carrier signal on the same cable. The 3120A/4120A and 10357A/10457A products are not optimized for such simultaneous signals, therefore usually it is necessary to split the 10 MHz onto a separate cable.)

### 6.1 Link Gain

The RF gain (G) for a complete linear fiberoptic link can be calculated as follows:

$$G = TG + RG - 2L_{\text{optical}} + 10\log(R_{\text{out}}/R_{\text{in}}) \quad \text{Eq. 6-1}$$

where, TG is the transmitter gain in dB·W/A  
 RG is the receiver gain in dB·A/W  
 $L_{\text{optical}}$  is the optical loss between the transmitter and receiver in dB.  
 $R_{\text{in}}$  &  $R_{\text{out}}$  are the transmitter input and receiver output impedances, respectively (either 50Ω or 75Ω).

TG and RG are related to the unit's total RF efficiency expressed in W/A or A/W ( $\eta_{\text{Tx, RF}}$  &  $\eta_{\text{Rx, RF}}$ , respectively). The RF efficiencies include the laser or photodiode efficiency (slope efficiency or modulation gain for the laser, responsivity for the photodiode) plus the gain contribution from matching networks and RF amplifiers. The terms TG and RG are simply the RF efficiencies expressed in units of dB as follows:

$$TG = 20\log(\eta_{\text{Tx, RF}}); \quad RG = 20\log(\eta_{\text{Rx, RF}})$$

For example, a typical link may consist of a 75Ω transmitter with a TG of -9dB·W/A, a 75Ω receiver with RG of +13dB·A/W, and a 1dB optical loss. The total link gain would then be:

$$G = -9\text{dB} \cdot \text{W/A} + 13\text{dB} \cdot \text{A/W} - (2 \times 1\text{dB}) + 10\log(75/75) = +2\text{dB}.$$

### 6.2 Common Link Performance Parameters

The link parameters in Table 6-1 are calculated based on the minimum specifications of separate transmitters and receivers with a 1dB optical loss. The table shows data for the case where flange-mount units are used, but the same results will apply to the plug-in style modules as well. Actual performance for an installed system will vary primarily due to differences in the optical loss for the connector, splices and fiber used. This can be calculated for the specific system with the equations below. Noise and linearity also are affected by optical loss and optical reflections from components. However, provided that the link loss is only a few dB and that the optical reflections are kept to a minimum by using APC connectors, the noise and linearity numbers in Table 1 may be used for a reasonable first order approximation.

Table 6-1 EXAMPLE LINK PARAMETERS					
<b>Tx Specs</b>		Usually Preferred			
	<b>3120A</b>	<b>3120A</b>	<b>3120A-102</b>	<b>3120A-102</b>	
<b>Gain version</b>	<b>Std</b>	<b>Std</b>	<b>Low</b>	<b>Low</b>	
Tx Gain (TG)	-10	-10	-25	-25	dB·W/A
NF	26	26	41	41	dB
Input TOI, 2-tone	0	0	15	15	dBm
Input 1 dB Comp.	-10	-10	5	5	dBm
Power, max.	1.6	1.6	1.6	1.6	mW
Impedance	75	75	75	75	Ω
<b>Rx Specs</b>	<b>4120A-102</b>	<b>4120A</b>	<b>4120A-102</b>	<b>4120A</b>	
	<b>High</b>	<b>Std</b>	<b>High</b>	<b>Std</b>	
Rx Gain (RG)	27	12	27	12	dB·A/W
PD Responsivity	0.85	0.85	0.85	0.85	A/W
Equiv. Noise Current	10	10	10	10	pA/Hz <sup>1/2</sup>
Output TOI, 2-tone	10	14	10	14	dBm
Output 1dB Comp.	0	0	0	0	dBm
Impedance	75	75	75	75	Ω
<b>Calculated Link Performance</b>					
<b>Tx gain version</b>	<b>Std</b>	<b>Std</b>	<b>Low</b>	<b>Low</b>	
<b>Rx gain version</b>	<b>High</b>	<b>Std</b>	<b>High</b>	<b>Std</b>	
<b>Optical loss</b>	<b>1</b>	<b>1</b>	<b>1</b>	<b>1</b>	<b>dB</b>
RF Gain	15.0	0.0	0.0	-15.0	dB
Output 1dB comp.	0.0	-10.0	0.0	-10.0	dBm
NF	27.3	27.3	42.7	42.7	dB
C/N, 36 MHz BW					
Input C = 0	*	*	*	55.9	dB
(in dBm) -10	*	*	45.9	45.9	dB
-20	50.9	50.9	35.9	35.9	dB
-30	40.9	40.9	25.9	25.9	dB
-40	30.9	30.9	15.9	15.9	dB
-50	20.9	20.9	5.9	5.9	dB
Input TOI	-5.6	0.0	9.4	15.0	dBm
Output TOI	9.4	0.0	9.4	0.0	dBm
C/I, 2-tone input					
Input C = 0	*	*	*	30.0	dB
(in dBm) -10	*	*	38.7	50.0	dB
-20	28.7	40.0	58.7	70.0	dB
-30	48.7	60.0	78.7	90.0	dB
-40	68.7	80.0	98.7	110.0	dB
-50	88.7	100.0	118.7	130.0	dB
Amplitude Flatness					
10 - 200 MHz	± 0.5	± 0.5	± 0.5	± 0.5	dB
over any 40 MHz	± 0.25	± 0.25	± 0.25	± 0.25	dB

\* Indicates input is above the 1 dB compression point

## Chapter 7 Troubleshooting and Maintenance

Once the fiberoptic link has been installed, there is no need for any regular maintenance. However, if problems do arise the most common causes and cures are listed here.

### 7.1 Low or Nonexistent RF Gain

For low RF gain, first check the option numbers and optical loss and then verify from Table 2-1 and Equation 6-1 that the correct link gain is being measured. If the gain is lower than it should be, first verify that the DC power to the optical transmitters and receivers has the correct voltage and current (Chapter 3). Next, check the optical elements as highlighted in section 7.3 below. Another possibility is that the receiver is being saturated by a transmitter which has too much optical power (approximately 2mW or greater) or the link has an excessive RF input level. Model 3120A/10357A transmitters emit <2mW of optical power - low enough to never saturate a 4120A/10457A receiver - so this is only a concern if another transmitter is used. Lastly, the DC circuitry of the unit itself may be verified as described in 7.4.

### 7.2 High Noise or Intermodulation Distortion

For a system with good gain but poor noise or intermods, the most likely cause is RF signal levels that are either too high or too low. Review Chapter 2 and Chapter 6 to determine the optimal RF power and adjust as necessary. High optical back reflections into the laser also can degrade noise and linearity, so verify that the FC-APC style connector is used to connect to the transmitters and receivers. Also check that all other connectors and splices between the transmitter and receiver also have good optical return loss. Refer to Chapter 4 for tips on the proper care of fiberoptic components.

### 7.3 Low Optical Power at the Receiver

If it appears that low gain or poor noise is due to low received optical power, review Chapter 4 to be sure that the optical connectors and fibers are being used properly. The most common problem, and easiest to fix, is that the connector key is not aligned with the mating slot. Other common problems include dirty connectors, bent fibers, broken fibers, disconnected connectors and overly tightened optical connectors. To determine exactly where light is being lost, start at the transmitter and work forward to the receiver, measuring or detecting power along the way. (As noted in section 4.3., an IR detection card at less than \$10 is an indispensable piece of test equipment.)



*The light emitted from the fiberoptic connector or any fiber attached to the connector is invisible and may be harmful to the human eye. Use either an infrared viewer or fluorescent screen for optical output verification.*

Another good clue is the status of the optical power alarm and/or photodiode current monitor outputs from the receiver. Bear in mind though that the optical power alarm triggers at approximately 0.1mW, therefore this only gives an indication of extreme cases. Also, some applications expect and can tolerate high optical losses, so in such cases if the RF performance is OK, the optical alarm may be ignored.

## 7.4 DC Circuit Verification

Chapter 3 details the DC monitoring and powering functions available with the IF-band IFL. Beyond the more obvious external problems such as no electrical power or disconnected cables, the internal DC circuits also can be quickly verified. The POWER LED indicator is provided on the flange-mount transmitter and receiver. A logic "high" on this output ( $\approx +6.5\text{VDC}$  for the transmitter;  $\approx +10\text{VDC}$  for the receiver) when DC power is applied to the unit indicates that regulated DC voltage is present inside the module. For plug-in units, the POWER ON indicator LED is provided on the front panel and will be illuminated when DC power is applied to the unit. If the POWER LED signal is not "active" (flange-mount) or the front panel LED is not illuminated (plug-in) when DC power is applied to the unit, then it may have suffered a DC failure or burned fuse. An alternative method for checking the health of a transmitter is as follows: when DC power is applied, infrared light should be emitted from the laser connector. It can be observed with an IR detection card. For the receiver, when DC power is applied and the optical connector is disconnected, the ALARM pin should be active ( $\approx +10\text{VDC}$ ). If these tests fail, then the unit may have suffered a DC failure or burned fuse.

## 7.5 Fuse Replacement

An internal fuse in the plug-in versions of the IF-band transmitters can be replaced by pulling the unit from the chassis, removing the four small screws holding the U-shaped side panel, and removing this panel. (Removing the cautionary stickers to replace the fuse does not void the warranty.) The fuse should be replaced with a quick-blow style with a rating of 0.8A.

Newer versions of the flange mount transmitter and receiver have a field replaceable fuse which is accessible on the rear of the unit's housing. The fuse should be replaced with a quick-blow style with a rating of 0.8A.

Neither the plug-in receiver nor older versions of the flange-mount products have a user replaceable fuse. These units must be returned to the factory for fuse replacement.