

EMP-1

Lithium-Niobate Fiber Optic Gyroscopes



Features

- Fully integrated optics and electronics
- Advanced optics and DSP electronics for higher accuracy, lower noise and greater efficiency
- DSP based closed loop design for improved drift stability, higher linearity and greater flexibility
- Versions with internal calibration including thermal effects can be made available
- 1,000 Hz bandwidth
- Customizable performance for a wide range of applications

Specifications*

- Drift stability, short term 0.1°/hr
- Drift stability, long term 0.5°/hr
- Noise 0.020°/√hr
- Scale factor stability 100 ppm
- Scale factor linearity 50 ppm
- Maximum rate 1,000°/sec
- Size 3.2" x 3.2" x 0.8"
- Both Digital & Analog I/O
- +5V power

* Subject to change without notice.

A Family of Fiber Optic Gyroscopes

EMCORE's long standing leadership in development of highly-accurate defense and military grade fiber optic components and systems is what makes the EMP-1 a clear choice when selecting solid-state gyroscope components. With fully integrated optics and electronics, the EMP-1 is a superior device in regards to weight and form-factor. It features advanced optics and digital signal processing (DSP) for much higher accuracy, lower noise and greater efficiency. The integrated DSP also improves optical drift stability, higher linearity and greater environmental flexibility. Additionally, the unit can be calibrated internally for better thermal effect and has both digital and analog outputs, accommodating the widest variety of installation parameters.

Customizable Gyroscope Platform

EMP FOG technology is cost effective and customizable for a wide range of applications encompassing drift rate and noise from 0.001°/hr and 0.005°/√hr respectively.

Mechanical Diagram

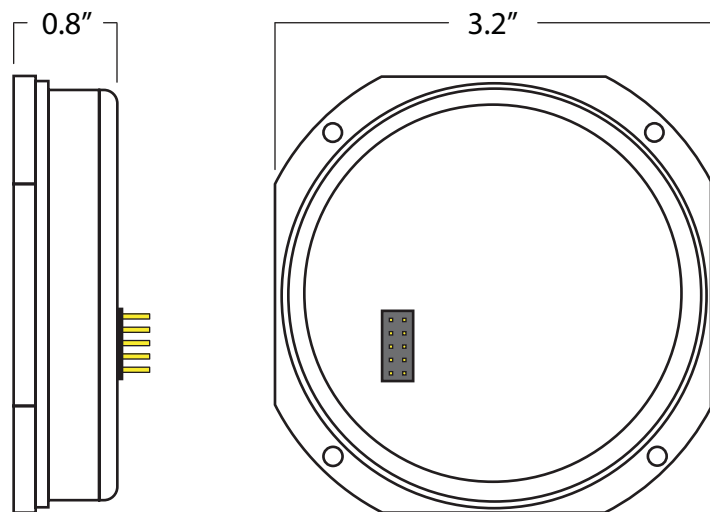

US Patent No. 7,746,476.