



WiBa Series Fiber Optic Link with Cooled DFB Laser

The Emcore Wide Bandwidth (WiBa) fiber optic inter-facility links (IFLs) are a high-performance, cost-effective alternative to coaxial cable for 10 MHz to 2700 MHz communication applications.

Emcore's IFLs serve as transparent links for satellite and cellular applications. These IFLs provide much longer transmission distances than possible with copper cables, while retaining the highest level of signal quality. In addition, Emcore's fiber optics provides simplified network design, ease of installation, and immunity from EMI/RFI and lightning. They fit in Emcore's widely used System 10000 chassis.

Features

- 10 MHz – 2700 MHz
- > 100 km
- 50Ω and 75Ω versions
- Adjustable RF gain
- Optimal RF level indicator
- Cooled, isolated DFB
- 8 transmitters per chassis
- 16 receivers per chassis
- DWDM option
- Flange Mount option

Applications

- TVRO
- Broadcast
- Earth Stations
- Headends
- VSAT
- GPS
- Wireless

Performance Highlights

		Minimum	Typical	Maximum	Units
Frequency Range	50Ω	10	-	2700	MHz
	75Ω	10	-	2500	MHz
Optical Distance		0	-	40	Km
		0	-	16	dB
Total RF input power, dBm	amplified Tx	-	-40 to 0	-	dBm
	un-amplified Tx	-	-6 to +10	-	dBm
Total RF input power, dBmV, 75Ω	amplified Tx	-	9 to 49	-	dBmV
	un-amplified Tx	-	43 50 590	-	dBmV
Wavelength	type 1038_-__13__	1300	-	1320	nm
	type 1038_-__15__	1530	-	1565	nm
DWDM Channels		21	-	53	
Optical Output Power	type 1038_-__01	1	-	2	mW
	type 1038_-__05	5	-	10	mW
	type 1038_-__15	15	-	20	mW
Optical Output Power	type 1038_-__01	0	-	3	dBm
	type 1038_-__05	7	-	10	dBm
	type 1038_-__15	11	-	13	dBm
Temperature Range	Rack	-10	-	+50	°C
	Flange	-45	-	+65	°C

See following pages for complete specifications and conditions.

Absolute Maximum Ratings

Stresses in excess of the absolute maximum ratings can cause permanent damage to the device. These are absolute stress ratings only. Functional operation of the device is not implied at these or any other conditions in excess of those given in the operational sections of the datasheet. Exposure to absolute maximum ratings for extended periods can adversely affect device reliability.

Parameter		Symbol	Min	Max	Units
Operating Temperature Range	Flange-mount	T_{OP}	-40	+65	°C
	Rack-mount		-10	+50	°C
Storage Temperature	Flange-mount	T_{STG}	-40	+85	°C
	Rack-mount		-40	+85	°C
RF Input	Amplified Tx set to max gain	S_{in}	-15	-	dBm
	Un-amplified Tx		+25	-	dBm
Optical Power into Receiver		P_r	-	12	dBm

Reference Block Diagrams

Un-amplified Tx 10381 or 10383

Rx 1048(X)

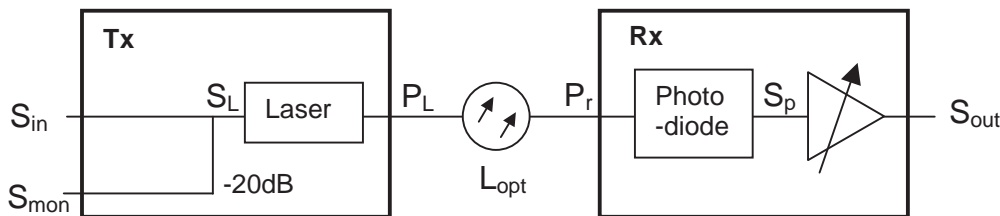

Amplified Tx 10382 or 10384

Rx 1048(X)

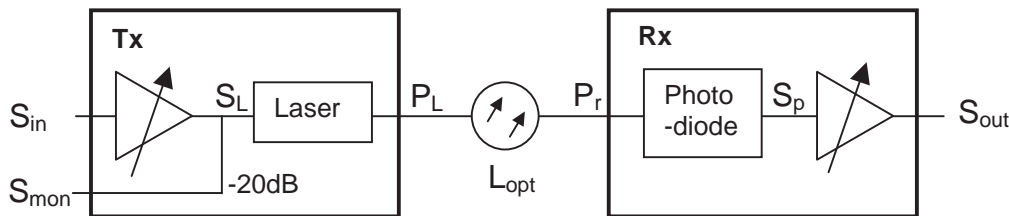

Primary versions (See last page for complete set of options)

Rack Model	Flange Model	Description
10381	3581	Tx, Un-Amplified, 10 to 2700 MHz, 50Ω
10382	3582	Tx, Amplified, 10 to 2700MHz, 50Ω
10383	3583	Tx, Un-Amplified, 10 to 2500 MHz, 75Ω
10384	3584	Tx, Amplified, 10 to 2500 MHz, 75Ω

Rack Model	Flange Model	Description
10481	4581	Rx, 10 to 2700 MHz, 50Ω
10482		Rx, Dual ¹ , 10 to 2700 MHz, 50Ω
10483	4583	Rx,, 10 to 2500 MHz, 75Ω
10484		Rx, Dual ¹ , 10 to 2500 MHz 75Ω
10485	4585	Rx, High Optical Power, 10 to 2700 MHz, 50Ω
10486		Rx, Dual ¹ , High Optical Power, 10 to 2700 MHz, 50Ω
10487	4587	Rx, High Optical Power, 10 to 2500 MHz, 75Ω
10488		Rx, Dual ¹ , High Optical Power, 10 to 2500 MHz, 75Ω

1. Dual receiver includes 2 receivers in a single plug-in module.

Optical Characteristics

Parameter	Symbol	Condition	Min	Typ	Max	Units
Wavelength	λ	-	1300	-	1320	nm
			1530	-	1565	nm
Optical Output Power (Transmitter)	P_L	1038X-XX-XX01	0	-	3	dBm
		1038X-XX-X05	7	-	10	dBm
		1038X-XX-XX15 (1310 nm only)	11	-	13	dBm
Optical Input Power (Receiver)	P_R	10481/2/3/4	-12	-	3	dBm
		10485/6/7/8	-5	-	10	dBm
Receiver dc Responsivity		1310	0.85	-	-	A/W
		1550	0.95	-	-	A/W
Fiber ¹	-	Single-mode, 9mm / 125mm, (Corning SMF-28 or equivalent)	-	-	-	-
Connector	-	FC/APC Tight Fit (Seikoh Giken or equivalent)	-	-	-	-
Connector Return Loss	-	-	60	-	-	dB

1. In order to prevent reflection-induced distortion degradation, the lasers should be connected to an optical cable having a return loss of at least 55 dB for discrete reflection and 30 dB for distributed reflections.

RF Gain Parameters, common to all versions

Parameter	Symbol	Condition	Min	Typ	Max	Units
Bandwidth	BW	50 Ω	10	-	2700	MHz
		75 Ω	10	-	2500	MHz
Amplitude Flatness, 20 MHz to max	$S_{Out} - S_{In}$	Any 48 MHz	-	-	± 0.375	dB
		Any 500 MHz	-	-	± 1.0	dB
		20 MHz to max	-	-	± 2.0	dB
Amplitude Flatness, 10 - 20 MHz	$S_{Out} - S_{In}$	10 - 20 MHz	-	-	± 3.0	dB
Tx Reference Port	$S_L - S_{Mon}$	1 GHz	-	-20	-	dB
Tx RF Return Loss	S_{22}	20 - 1000 MHz	-	-	-10	dB
		1000 - 2000 MHz	-	-	-9	dB
		2000 MHz - max	-	-	-6	dB
Rx RF Return Loss	S_{22}	20 - 1000 MHz	-	-	-10	dB
		1000 - 2000 MHz	-	-	-9	dB
		2000 MHz - max	-	-	-6	dB

Link Gain ($S_{Out} - S_{In}$) with all amps set to maximum

GAIN TERMINOLOGY: The RF gain ($G+S_{Out}-S_{In}$) for a complete links is specified as follows

$$G = TG + RG - 2L_{Opt} + 10 \times \text{Log} (R_{Out} / R_{In})$$

TG is the Tx gain in dBW/A, RG the Rx gain in dB A/W, L_{Opt} the total optical loss in dB, R_{In} the Tx impedance, and R_{Out} the Rx impedance.

Gain Parameters, un-amplified transmitters

Parameter	Symbol	Condition	Min	Typ	Max	Units
Transmitter Gain, 10381_--_01 (50Ω)	TG	1 GHz	-34.6	-	-	dB*W/A
10381_--_05 (50Ω)		1 Ghz	-20.6	-	-	dB*W/A
10381_--_15 (50Ω) ¹		1 GHz (1310 nm only)	-14.6	-	-	dB*W/A
10382_--_01 (75Ω)		1 GHz	-36.6	-	-	dB*W/A
10382_--_05 (75Ω)		1 Ghz	-22.6	-	-	dB*W/A
10382_--_15 (75Ω) ¹		1 GHz (1310 nm only)	-16.6	-	-	dB*W/A

Gain Parameters, amplified transmitters, at max setting

Parameter	Symbol	Condition	Min	Typ	Max	Units
Tx Amp Gain, 10382 (50Ω)	$G_{TA} = S_L - S_{In}$	-	29	32	-	dB
Tx Amp Gain, 10384 (75Ω)	$G_{TA} = S_L - S_{In}$	-	37	30	-	dB
Tx Amp Adjustment Range	$G_{TA} = \text{max} - \text{min}$	-	18	-	-	dB
Transmitter Gain, 10382_--_01 (50Ω)	TG	1 GHz	-5.6	-	-	dB*W/A
10382_--_05 (50Ω)		1 Ghz	8.4	-	-	dB*W/A
10382_--_15 (50Ω) ¹		1 GHz (1310 nm only)	14.4	-	-	dB*W/A
10384_--_01 (75Ω)		1 GHz	-7.6	-	-	dB*W/A
10384_--_05 (75Ω)		1 Ghz	6.4	-	-	dB*W/A
10384_--_15 (75Ω) ¹		1 GHz (1310 nm only)	12.4	-	-	dB*W/A

1. Due to Stimulated Brillouin Scattering (SBS), optical power greater than 10 mW should not be launched into fibers longer than a few Km.

Gain Parameters, standard receivers, at max setting

Parameter	Symbol	Condition	Min	Typ	Max	Units
Rx Amp Gain, 10481/2 (50Ω)	$G_{RA} = S_{Out} - S_P$	-	-	32	-	dB
Rx Amp Gain, 10483/4 (75Ω)	$G_{RA} = S_{Out} - S_P$	-	-	30	-	dB
Rx Amp Adjustment Range	$G_{RA} = \text{max} - \text{min}$	-	18	-	-	dB
Receiver Gain, 10481/2_--_ (50Ω)	RG	1 GHz, 1310 nm	26.6	-	-	dB*A/W
10483/4_--_ (75Ω)		1 GHz, 1310 nm	24.6	-	-	dB*A/W

Gain Parameters, low gain / high optical input receivers, at max setting

Parameter	Symbol	Condition	Min	Typ	Max	Units
Rx Amp Gain, 10485/6 (50Ω)	$G_{RA} = S_{Out} - S_P$	-	-	14	-	dB
Rx Amp Gain, 10487/8 (75Ω)	$G_{RA} = S_{Out} - S_P$	-	-	12	-	dB
Rx Amp Adjustment Range	$G_{RA} = \text{max} - \text{min}$	-	18	-	-	dB
Receiver Gain, 10485/6_--_ (50Ω)	RG	1 GHz, 1310 nm	11	-	-	dB*A/W
10487/8_--_ (75Ω)		1 Ghz, 1310 nm	9	-	-	dB*A/W

For optimal performance of typical L-band satellite signals, the total RF power into the laser (S_L) should be adjusted to +4 dBm or less, such as by decreasing the gain of the Tx amp. As a result, after adjusting link gain will be a function of the RF power (S_{In}).

$\Delta(\text{RF Link gain, dB}) = -2 \times \Delta(\text{Optical Loss, dB})$. Typical loss for fiber at 1310 nm < 0.4 dB/km, plus additional connector and splitter losses.

Noise & Linearity, unamplified Tx (10381/3) & amplified Rx (1048_)¹

Parameter	Symbol	Condition	Min	Typ	Max	Units
Total RF Power into Laser ²	S_L	Optimum Noise Power Ratio (NPR)	-	2	4	dBm
Link Noise Figure, ref to S_L	-	2.0 GHz	-	-	50	dB
Link Input TOI, ref to S_L	-	2-tones, $S_L = +1$ dBm 2000 & 2001 MHz	32	-	-	dB
Spurious ³	-	1 GHz, 1310 nm	-	-	-70	dBc

Noise & Linearity, amplified Tx (10382/4) & amplified Rx (1048_)¹

Parameter	Symbol	Condition	Min	Typ	Max	Units
Total RF Power into Laser ²	S_L	Optimum Noise Power Ratio (NPR)	-	2	4	dBm
Total RF power into Tx	S_{in}	Amplified version, NPR > 30 dB	-	-40 to 0	-	dBm
Link Noise Figure, ref to S_L	-	2.0 GHz	-	-	52	dB
Tx TOI, ref to S_L max gain	-	2-tones, $S_L = +1$ dBm 2000 & 2001 MHz	32	-	-	dBm
Tx TOI, ref to S_L max gain - 18 dB	-	2-tones, $S_L = +1$ dBm 2000 & 2001 MHz	27	-	-	dBm
Spurious ³	-	1 GHz, 1310 nm	-	-	-70	dBc

1. Data measured at 25 °C unless noted otherwise. Transmitter tested with optical loss so that the $P_R = 0$ dBm, unless noted otherwise.
2. LED on Tx front panel indicates when RF power is within optimal range. Yellow = RF Low, Green = RF Optimum, Red = RF High.
3. Receiver gain set to maximum.

Typical Noise Power Ratio

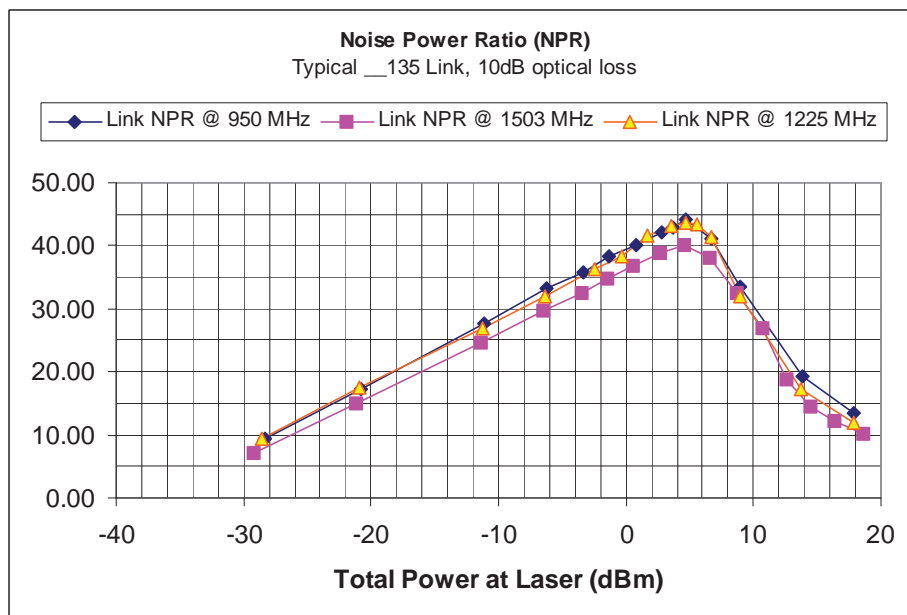

WiBa Series

10 MHz to 2700 MHz Fiber Optic Links

SATCOM

Mechanical Dimensions - Model 10990A (System 10000) Chassis Detail

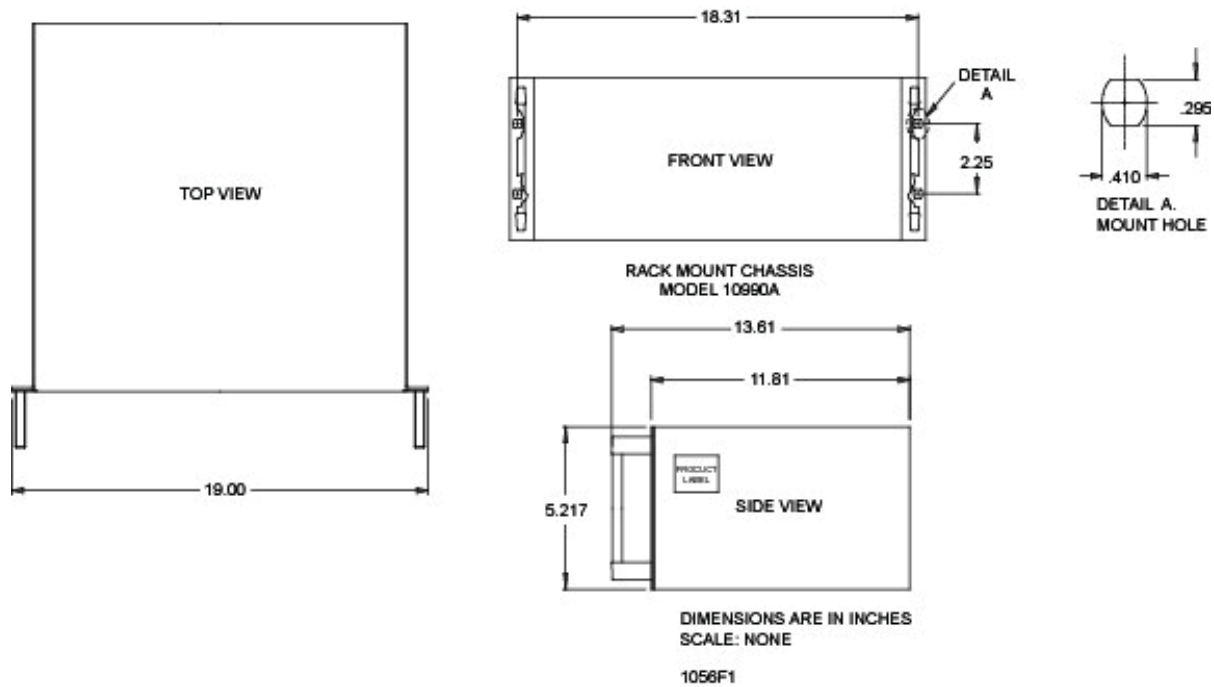

Mechanical Dimensions 358(XX) / 458(XX)

358(XX)

458(XX)

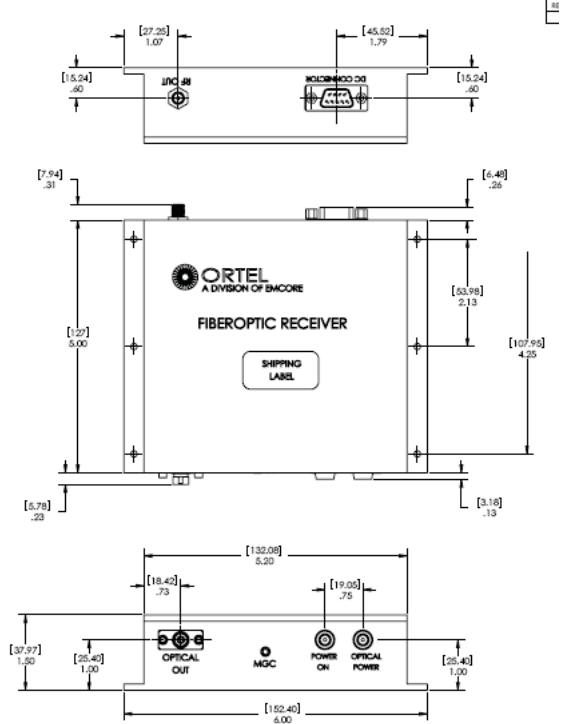
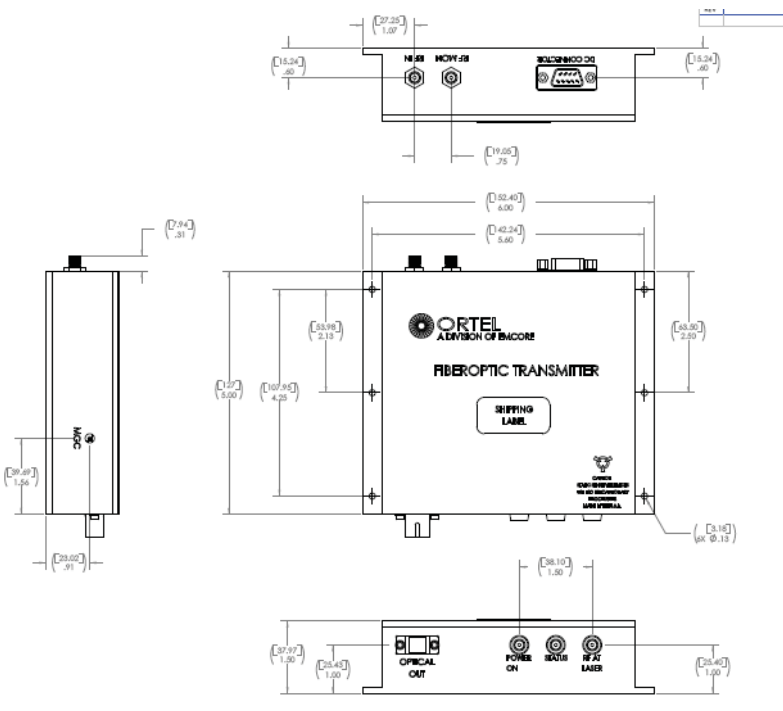

WiBa Series

10 MHz to 2700 MHz Fiber Optic Links

Mechanical Dimensions 1038(XX) / 1048(XX)

1048(XX)

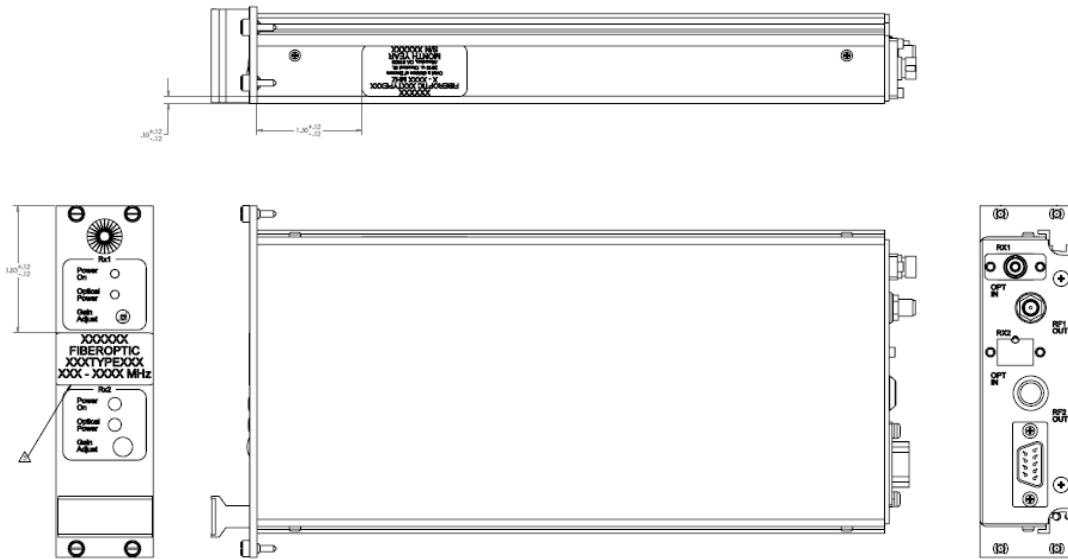

1038(XX)

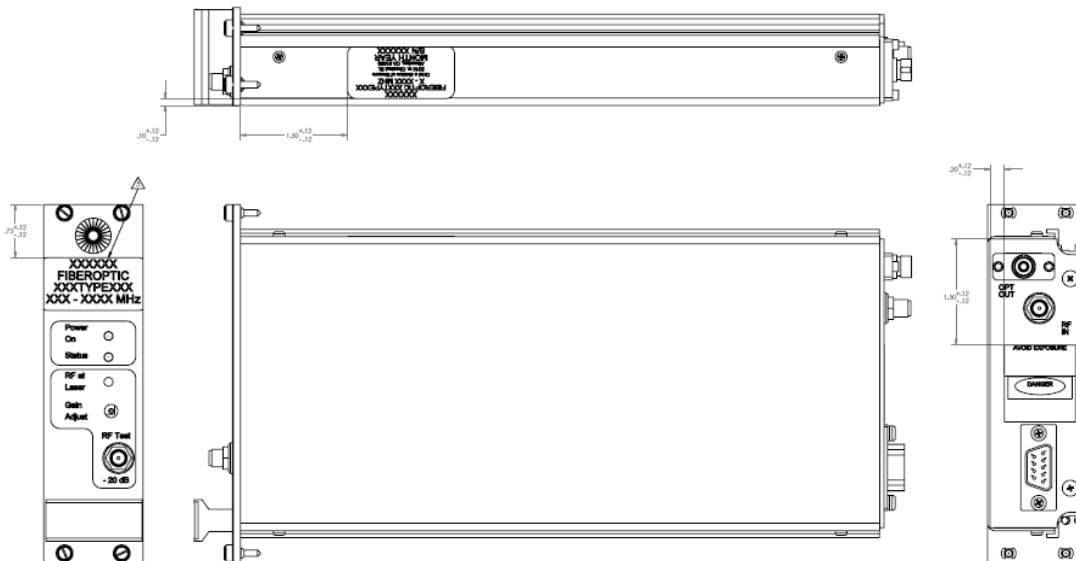

Pin Information

Plug-In D-Sub	10990A Back Plane P11 -P18	10990A Back Plane J11 -J18	Tx	Rx Single Receiver	Rx DualReceiver
1 ¹	-	-	+15 VDC	+15 VDC	+15 VDC
2 ¹	-	-	+5 VDC	+5 VDC	+5 VDC
3 ¹	-	-	Not Used	Not Used	Not Used
4 ¹	-	-	Ground	Ground	Ground
5 ¹	-	-	Ground	Ground	Ground
6 ²	1	5	Laser Temp Monitor	PDIM	PDIM, Rx #1
7 ²	2	4	Alarm ~0 VDC No Alarm ~3.3 VDC	Alarm ~0 VDC No Alarm ~5.0 VDC	Alarm Rx #1~0 VDC No Alarm ~ 5.0 VDC
8 ²	3	3	LaserCurrentMonitor	Not Used	PDIM, Rx #1
9 ²	4	2	Not Used	Not Used	Alarm Rx #1~0 VDC No Alarm ~ 5.0 VDC
	5	1	Not Used	Not Used	Not Used

1. Powered from 10901G, or equivalent power supply.
2. Accessible via connector on back panel of 10990A chassis

Receiver Alarm Schematic

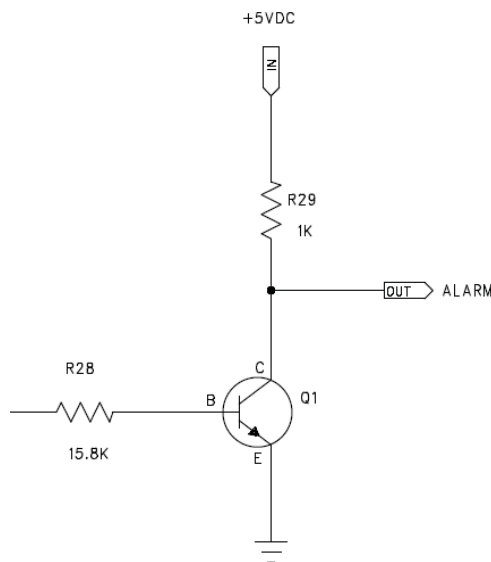

DC Power

Input Voltage	Tx	Rx
+15 VDC	620 mA	80 mA
+5 VDC	120 mA	130 mA

Ripple and noise: 100 mV p-p > 100 kHz; 200 mV p-p < 100 kHz
 +5 VDC and +15 VDC may be from model 10901G or equivalent power supplies.

WiBa Series

10 MHz to 2700 MHz Fiber Optic Links



SATCOM

Transmitter Options (For example. 3582S-SA1305 or 10384F-FA2101)

U		V-		WW		XXYY	
Package, Amps, Bandwidth & Impedance		RF Connector		Optical Connector		Wavelength & Power	
10381	Rack, Un-Amplified, 10 - 2700 MHz, 50Ω	S	SMA, 50Ω	FA	FC/APC	1301	1310 nm / 1-2 mW
10382	Rack, Amplified, 10 - 2700 MHz, 50Ω	B	BNC, 50Ω or , 75Ω	SA	SC/APC	1305	1310 nm / 5-10 mW
10383	Rack, Un-Amplified, 10 - 2500 MHz, 75Ω	F	F-Type, 75Ω			1315	1310 nm / 15-20 mW
10384	Rack, Amplified, 10 - 2500 MHz, 75Ω					1501	1550 nm / 1-2 mW
3581	Flange, Un-Amplified, 10 - 2700 MHz, 50Ω					1505	1550 nm / 5-10 mW
3582	Flange, Amplified, 10 - 2700 MHz, 50Ω					XX01*	See ITU ch. / 1-2 mW
3583	Flange, Un-Amplified, 10 - 2500 MHz, 75Ω					XX05*	See ITU ch. / 5-10 mW
3584	Flange, Amplified, 10 - 2500 MHz, 75Ω						

*XX Indicates ITU Channel Number for DWDM system

ITU Channel Plan for DWDM systems (XX from model number)

Ch.	THz	l (nm)	Ch.	THz	l (nm)	Ch.	THz	l (nm)	Ch.	THz	l (nm)
62	196.2	1527.99	50	195.0	1537.40	38	193.8	1546.92	26	192.6	1556.56
61	196.1	1528.77	49	194.9	1538.19	37	193.7	1547.72	25	192.5	1557.36
60	196.0	1529.55	48	194.8	1538.98	36	193.6	1548.51	24	192.4	1558.17
59	195.9	1530.33	47	194.7	1539.77	35	193.5	1549.32	23	192.3	1558.98
58	195.8	1531.12	46	194.6	1540.56	34	193.4	1550.12	22	192.2	1559.79
57	195.7	1531.90	45	194.5	1541.35	33	193.3	1550.92	21	192.1	1560.61
56	195.6	1532.68	44	194.4	1542.14	32	193.2	1551.72	20	192.0	1561.42
55	195.5	1533.47	43	194.3	1542.94	31	193.1	1552.52	19	191.9	1562.23
54	195.4	1534.25	42	194.2	1543.73	30	193.0	1553.33	18	191.8	1563.05
53	195.3	1535.04	41	194.1	1544.53	29	192.9	1554.13			
52	195.2	1535.82	40	194.0	1545.32	28	192.8	1554.94			
51	195.1	1536.61	39	193.9	1546.12	27	192.7	1555.75			

Receiver Options (For example. 4581S-SA or 10484F-FA)

U		V-		WW	
Package, Amps, Bandwidth & Impedance		RF Connector		Optical Connector	
10481	Rack, 10 - 2700 MHz, 50Ω	S	SMA, 50Ω	FA	FC/APC
10482	Double*, Rack, 10 - 2700 MHz, 50Ω	B	BNC, 50Ω or , 75Ω	SA	SC/APC
10483	Rack, 10 - 2500 MHz, 75Ω	F	F-Type, 75Ω		
10484	Double*, 10 - 2500 MHz, 75Ω				
10485	Rack, High optical power in, 10 - 2700 MHz, 50Ω				
10486	Double*, Rack, High optical power in, 10 - 2700 MHz, 50Ω				
10487	Rack, High optical power in 10 - 2500 MHz, 75Ω				
10488	Double*, High optical power in, 10 - 2500 MHz, 75Ω				
4581	Flange, 10 - 2700 MHz, 50Ω				
4583	Flange, 10 - 2500 MHz, 75Ω				
4585	Flange, High optical power in, 10 - 2700 MHz, 50Ω				
4587	Flange, High optical power in, 10 - 2500 MHz, 75Ω				

*Double receivers each include 2 receivers in a single plug-in module

WiBa Series

10 MHz to 2700 MHz Fiber Optic Links

Ordering Information - Accessories

Part Number / Model	Description
10990A	3U 19" Rack Mount Chassis (Up to 8 plug-in Modules)
10901G-NA / UK / EU	90 - 260 VAC Power Supply (AC Power Cord Options NA - North America, UK - United Kingdom, EU - European)
10209A	75Ω BNC 1:1 Redundancy Switch
10209E-C01	50Ω BNC 1:1 Redundancy Switch
5220-048	FC/APC -FC/APC Jumper
5220-037	SC/APC -SC/APC Jumper
5221-006	FC Mating Adapter
5221-010	SC Mating Adapter
5220-010	Optical Attenuator, FC/APC - FC/APC, 6 dB
2925WM / WD	Wavelength Multiplexor / Demultiplexor
1188QA-SFSP	1X2 - 1X16 Optical Splitter, 1U, SC/APC
1188QA-SFAP	1X2 - 1X16 Optical Splitter, 1U, FC/APC
NMOA8100	Fiber Amplifier, 1U, 19" rack mount, +27 dBm max output
NMOA8200	Fiber Amplifier, 2U, 19" rack mount, +35 dBm max output

Laser Safety

Class IIIb Laser Product

FDA/CDRH Class IIIb laser product. All WiBa Series transmitter versions are Class IIIb laser products per CDRH, 21 CFR 2040 Laser Safety requirements. All versions are Class 3B laser products per IEC*60825-1:1993. Maximum Power = 30 mW.

Caution: Use of controls, adjustments and procedures other than those specified herein may result in hazardous laser radiation exposure.

*IEC is a registered trademark of the International Electrotechnical Commission.



Rev: November 18, 2010