

# 5016 18 GHz Fiber Transceiver



The 5016D 18 GHz transceiver delivers unmatched performance for radar testing, signal processing, phased antenna array, and phase noise testing. These rugged devices eliminate many of the problems that are inherent in alternative transceiver technologies. When used in conjunction with the 355A fiber-optic delay spools it offers performance that is superior to acoustic wave and coaxial delay lines.



Ortel's fiber-optic transceivers provide bandwidth that is essentially independent of fiber length, loss or delay, and triple transit signals that are immeasurable. In addition to enhanced electrical performance, the delay lines provide several mechanical advantages. Ortel's technology takes advantage of the rigid yet flexible properties of fiber-optic cable to provide repeatable enhanced phase and group delay characteristics. The small size of these components allows for a long delay in a compact package with the superior temperature stability of fiber.

## Features

- Bandwidth to 18 GHz
- High dynamic range
- -40 to +65 C
- 1310 nm
- Flat frequency response
- Low phase noise

## Ordering Information

Model Number	Description
5016D-020	Transceiver, 18 GHz, SMA, 1310 nm, 9 dBm, FC/APC

## Applications

- Radar testing
- Signal processing
- Phased antenna array
- Phase noise processing
- Antenna remoting

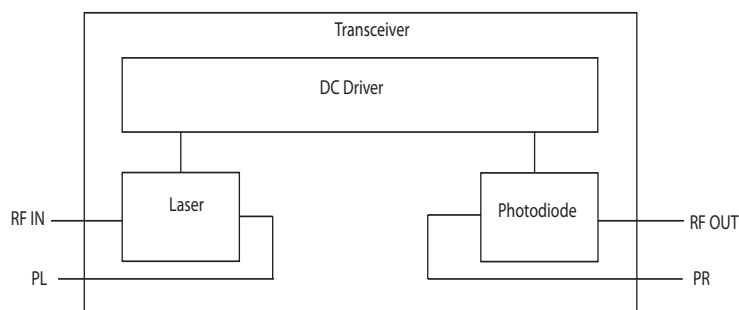
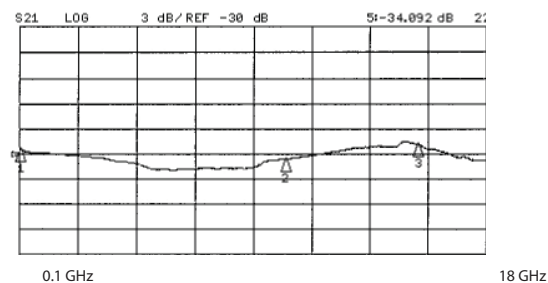

# 5016

## 18 GHz Fiber Transceiver



MICROWAVE

### Absolute Maximum Ratings

Stresses in excess of the absolute maximum ratings can cause permanent damage to the device. These are absolute stress ratings only. Functional operation of the device is not implied at these or any other conditions in excess of those given in the operational sections of the data sheet. Exposure to absolute maximum ratings for extended periods can adversely affect device reliability.

Parameter	Min	Max	Unit
Operating Temperature Range of Baseplate	-40	+65	°C
Storage Temperature	-55	+85	°C
RF Input Power	-	20	dBm

### DC Interface Characteristics

Pin Number	Min	Typ	Max	Max Ripple	Current
1	14V	15V	16V	100 mV p-p	0.3 A max
2	4.5V	5V	5.5V	200 mV p-p	1.6 A max

### Front Panel LEDs

- Power On

### Pin/Package Information

Nine-Pin, Male D-sub Connector

Pin Number	Function
1	+15 Vdc
2	+5 Vdc
3	Not Used
4	Ground
5	Ground
6	Laser Photodiode Current Monitor
7	Photodiode Current Monitor
8	Laser Current Monitor
9	Laser Over Temperature Alarm <sup>1</sup>

1. Open Collector Alarm

### dc Monitor Voltages

- Photodiode current, pin 7  
1V/1mA (into 1 MOhm load). Proportional to the received optical power.
- Laser dc current, pin 8:  
1V/100mA (into 1 MOhm load). Proportional to laser optical power.

### Alarm Circuits

- Summary Alarm, pins 9

The alarm is an open collector :

Laser Temperature. This alarm is ON (sinks current) if the laser substrate temperature is more than 2 °C higher than the factory setpoint. The alarm is not activated if the temperature is LOWER than the setpoint.

# 5016

## 18 GHz Fiber Transceiver

### Electrical Characteristics

Parameter	5016D	Unit
Upper Band Edge Frequency	18	GHz
Lower Band Edge Frequency	0.1	GHz
Amplitude Flatness	5	dB p-p
Transmitter Gain (TG), 1 GHz <sup>1</sup>	-23	dB (W/A)
Receiver Gain (RG), 1 GHz <sup>1</sup>	-11	dB (A/W)
Input RF Return Loss, max	0.1 - 10 GHz	-7.0 dB
	10 - 18 GHz	-4.0 dB
Output RF Return Loss, max	0.1 - 10 GHz	-9.0 dB
	10 - 18 GHz	-6.0 dB
Impedance	50	Ohm
Input 1 dB Compression, min	+20	dBm
Input Third Order Intercept, min	0.1 GHz - 5 GHz	+30 dBm
	5 GHz - 18 GHz	+25 dBm
Noise Figure	0.1 GHz - 4 GHz	44 dB
	4 GHz - 10 GHz	50 dB
	10 GHz - 15 GHz	54 dB
	15 GHz - 18 GHz	59 dB

### Optical Characteristics

Parameter	Specification	Unit
Fiber	Single mode (9/125 μm)	
Optical Connectors	FC/APC	-
5016D Optical Transmitter Output Power <sup>1</sup>	9 to 11	dBmo
5016D Optical Receiver Input Power	3	dBmo, max

1. When ordering the 5016 units please specify if the are to be used as a transceiver or with a 355A delay spool. If the 5016 is used with a 355A delay spool the optical power will be adjusted for the specified delay time.

1. Link RF Gain<sub>dB</sub> = TG + RG - 2\* FiberLoss<sub>dB</sub> (assumes R<sub>in</sub> = R<sub>out</sub>)
2. dBmo & dBo indicate optical power & loss to minimize confusion with RF dBm & dB.

### OUTLINE DRAWING

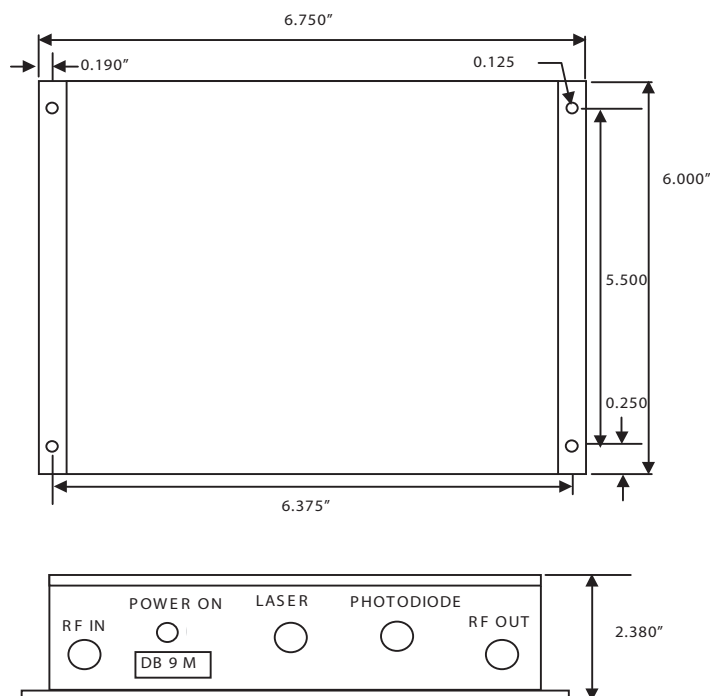

# 5016

## 18 GHz Fiber Transceiver



MICROWAVE

### Laser Safety

This product meets the appropriate standard in Title 21 of the Code of Federal Regulations (CFR).  
FDA/CDRH Class IIIb laser product. This device has been classified with the FDA/CDRH under accession number 0220191. All Versions of this laser are Class 3B laser product, tested according to IEC 60825-1:1993 + A1:1997 + A2:2001 / EN 60825-1:1994 + A2:2001 + A1:2002  
Single-mode fiber pigtail with FC/APC connector.

Wavelength = 1.3  $\mu\text{m}$ .

Maximum power = 30 mW.

Because of size constraints, laser safety labeling (including an FDA class IIIb label) is not affixed to the module, but attached to the outside of the shipping carton.

Product is not shipped with power supply.

Caution: Use of controls, adjustments and procedures other than those specified herein may result in hazardous laser radiation exposure.

Rev: December 14, 2010